

SECTION 2

Channel Accessories & Beam Clamps

Channel Accessories
& Beam Clamps

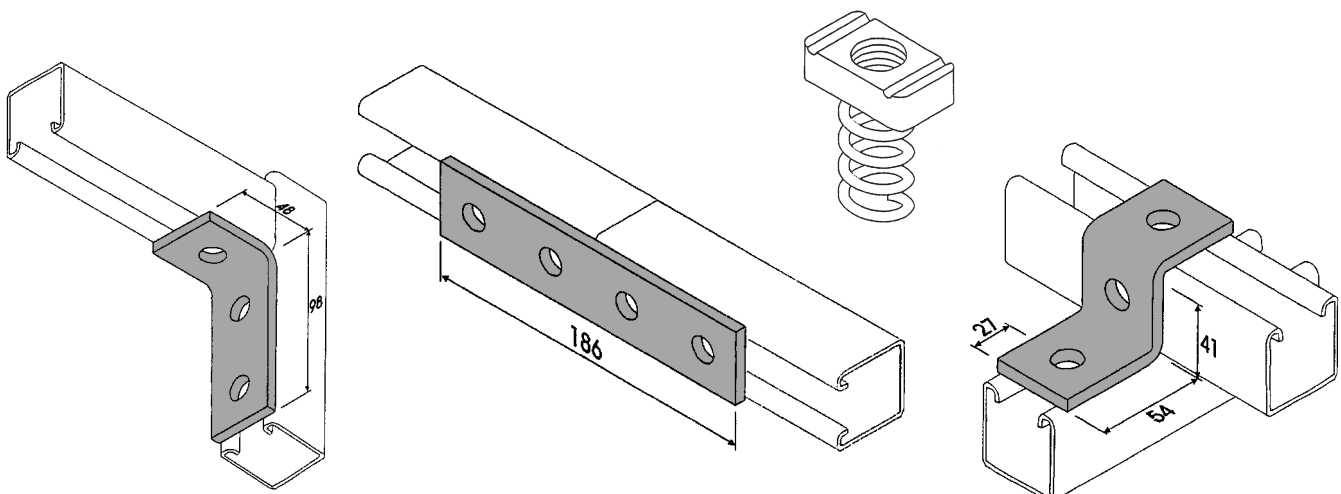

METAL FRAMING CHANNEL NUTS

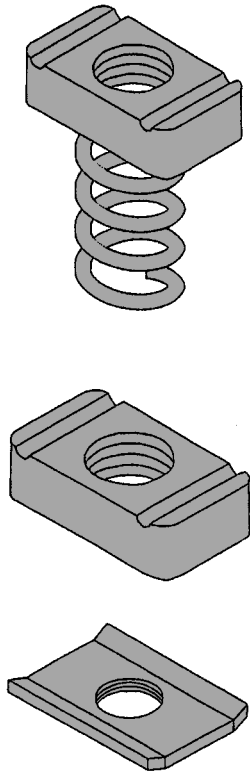

CHANNEL NUTS WITH SPRINGS		
PART NO.	THREAD	SUIT CHANNEL
FM1006	M06	FM1000 / FM2000
FM1007	M08	FM1000 / FM2000
FM1008	M10	FM1000 / FM2000
FM1010	M12	FM1000 / FM2000
FM1012S	M16	FM1000 / FM2000
FM5508	M10	FM5500
FM5510	M12	FM5500
FM4006	M06	FM3300 / FM4000
FM4007	M08	FM3300 / FM4000
FM4008	M10	FM3300 / FM4000
FM4010	M12	FM3300 / FM4000
FM4012S	M16	FM3300 / FM4000

CHANNEL NUTS WITHOUT SPRINGS		
PART NO.	THREAD	SUIT CHANNEL
FM3016	M6	TRUNKING NUT, ALL CHANNELS
FM3006	M6	ALL CHANNELS
FM3007	M8	ALL CHANNELS
FM3008	M10	ALL CHANNELS
FM3010	M12	ALL CHANNELS
FM1012	M16	ALL CHANNELS

FINISH: ZINC PLATED
GALVANISED AND STAINLESS STEEL AVAILABLE ON REQUEST

Channel Accessories
& Beam Clamps

FM1184-PLA
FM2240
FM4240
FM5580

CLOSURE STRIP AND END CAPS

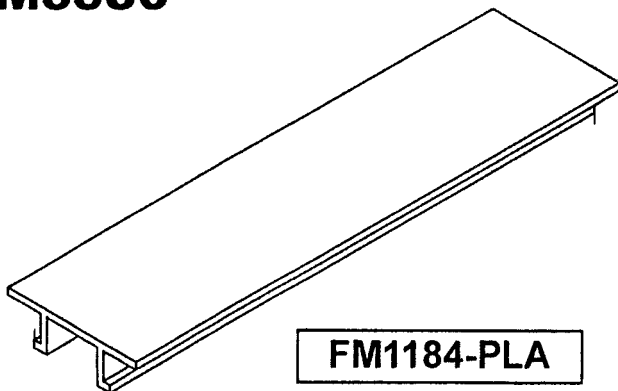

FM1184-PLA

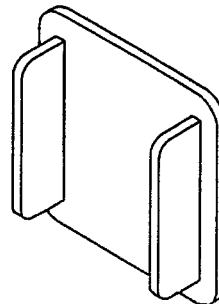

END CAPS

FM2240 FOR FM1000
FM2240 FOR FM2000
FM4240 FOR FM3300
FM4240 FOR FM4000
FM5580 FOR FM5500

GREY PVC

90 DEGREE ANGLE FITTINGS

FM1026
FM1068
FM1326
FM1346
FM1458

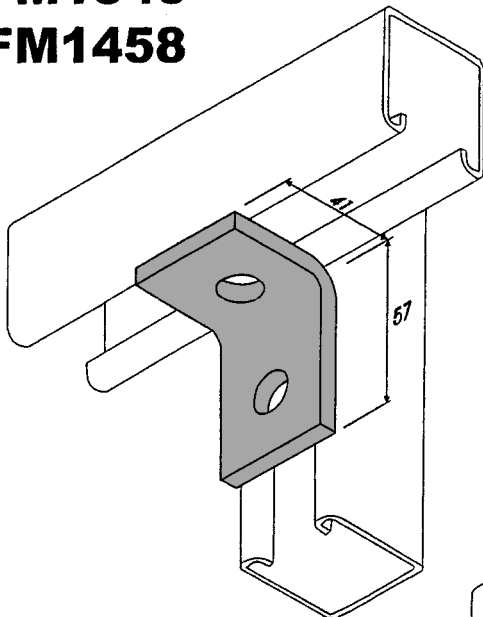

FM1068

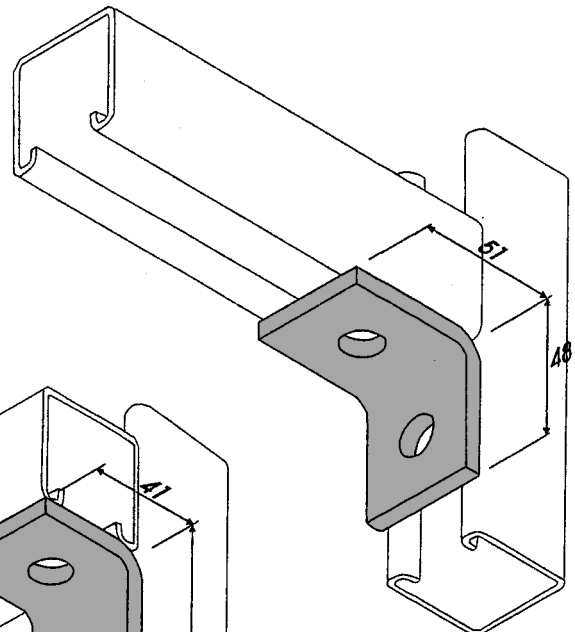

FM1026

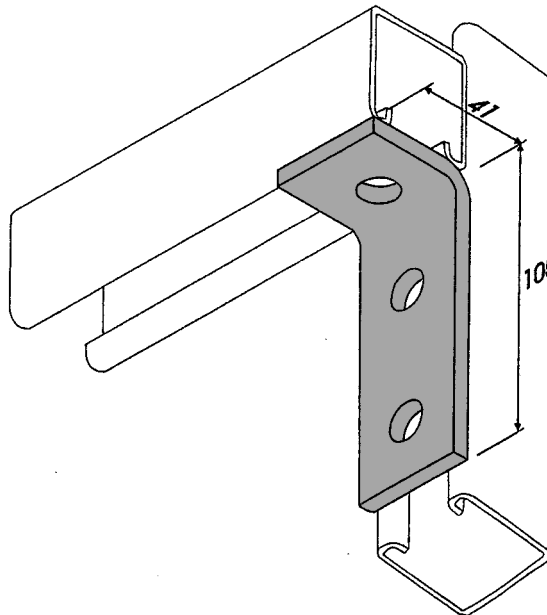

FM1326

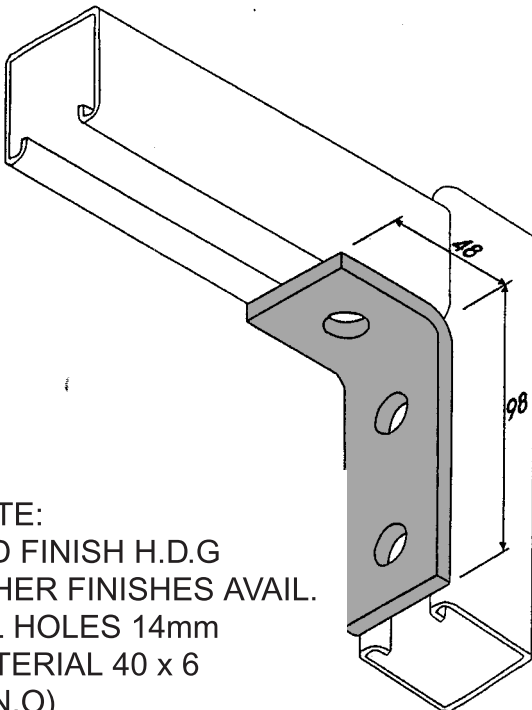

FM1346

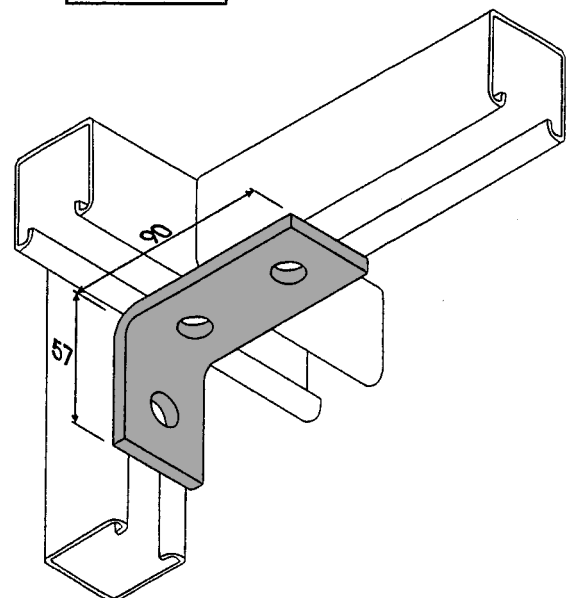

FM1458

NOTE:
STD FINISH H.D.G
OTHER FINISHES AVAIL.
ALL HOLES 14mm
MATERIAL 40 x 6
(U.N.O)

FLAT PLATE FITTINGS

FM1031
FM1036
FM1358
FM2324
FM2325

Channel Accessories
 & Beam Clamps

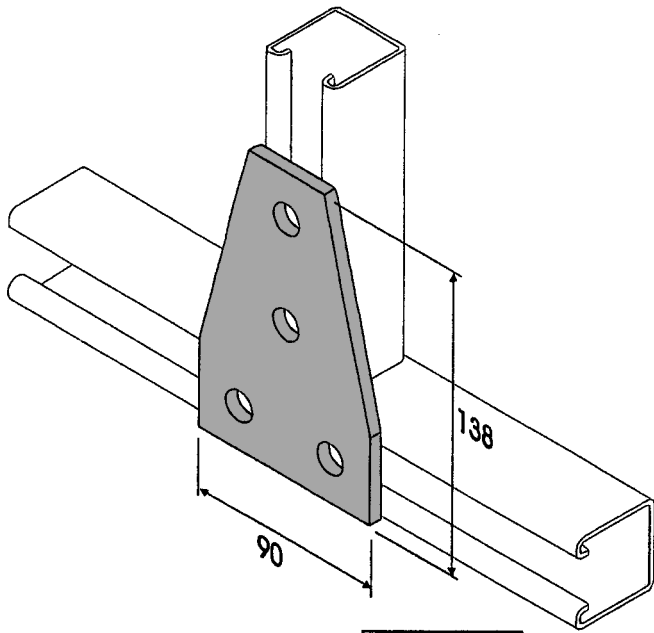

FM1358

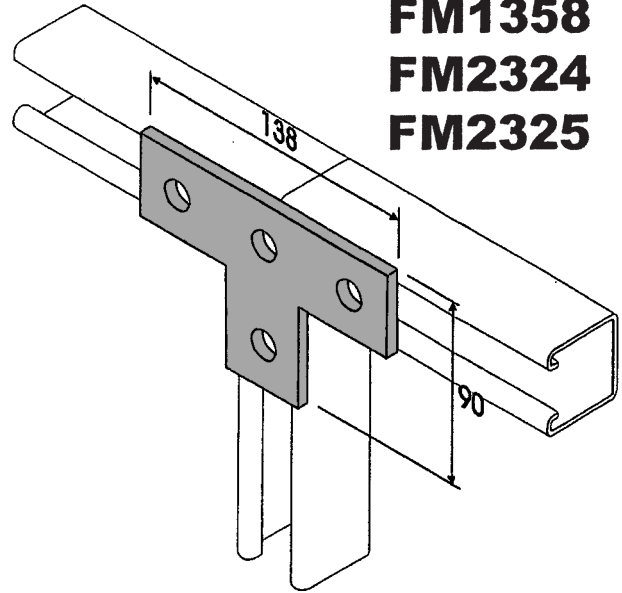

FM1031

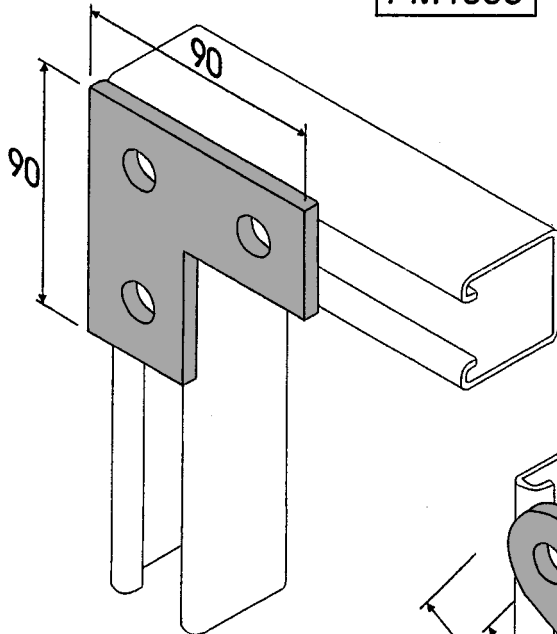

FM1036

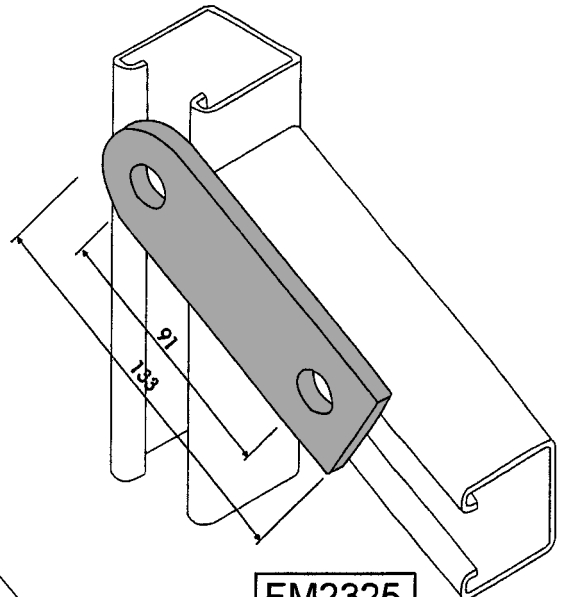

FM2325

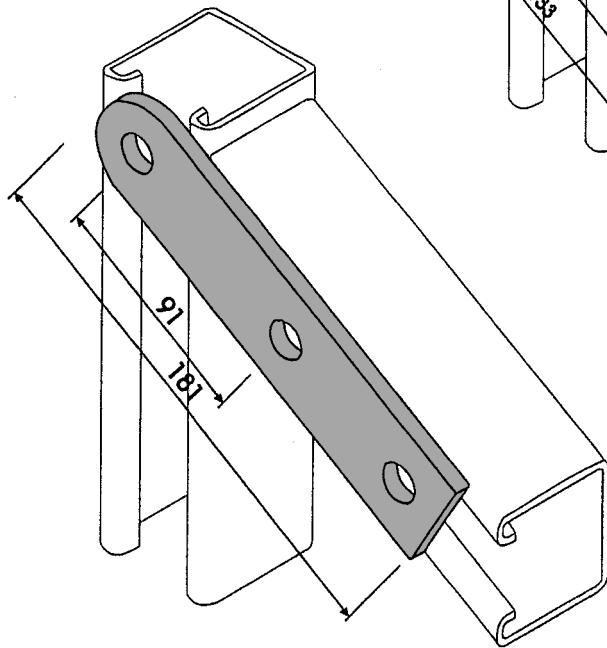

FM2324

NOTE:
 STD FINISH H.D.G
 OTHER FINISHES AVAIL.
 ALL HOLES 14mm
 MATERIAL 40 x 6
 (U.N.O)

90 DEGREE ANGLE FITTINGS

FM1033
FM1038
FM1325
FM2484

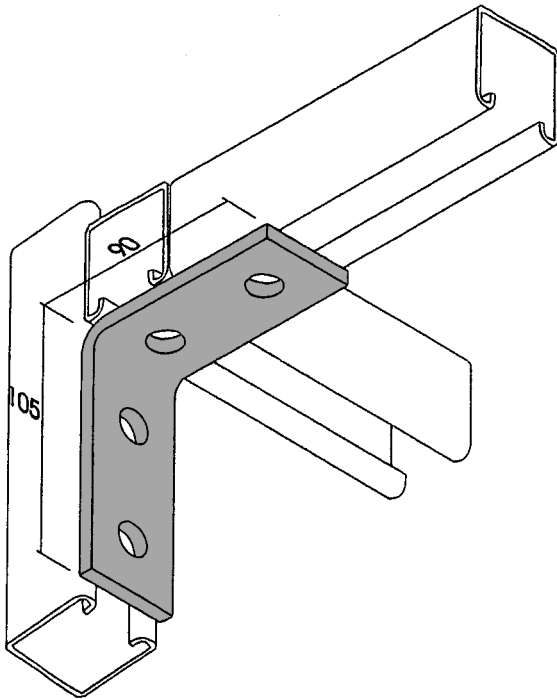

FM1325

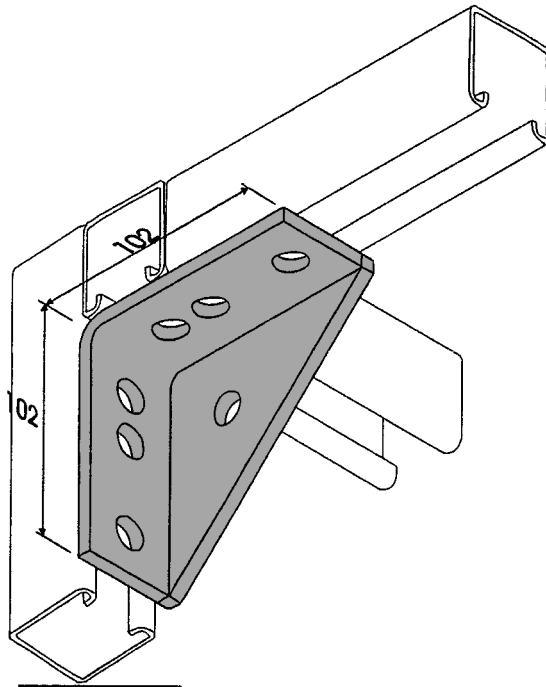

FM2484

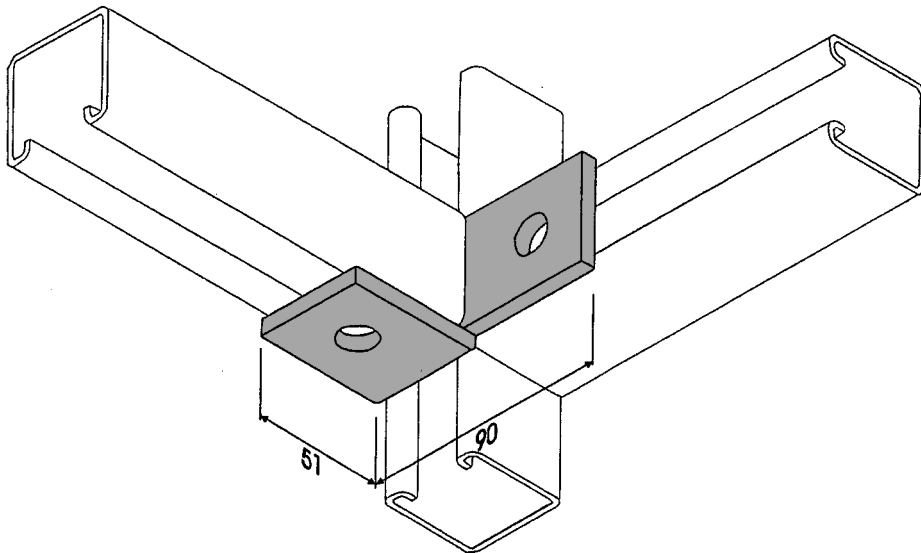

FM1038

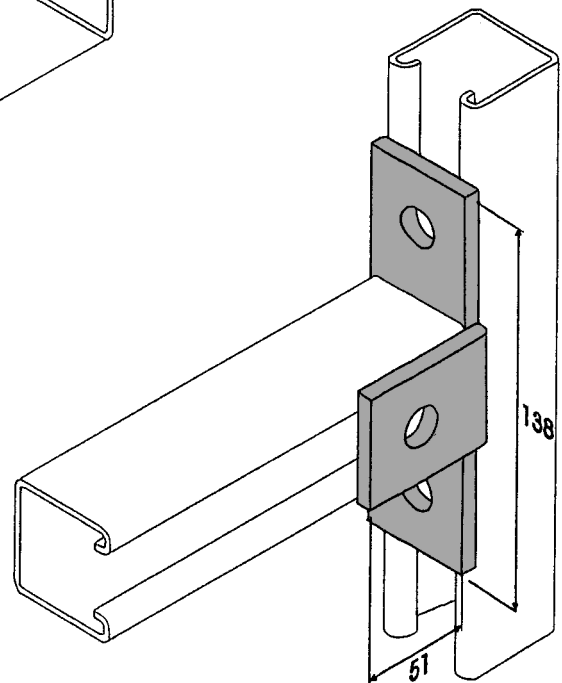

FM1033

NOTE:
STD FINISH H.D.G
OTHER FINISHES AVAIL.
ALL HOLES 14mm
MATERIAL 40 x 6
(U.N.O)

FM1034
FM1035
FM1037

90 DEGREE ANGLE FITTINGS

Channel Accessories
& Beam Clamps

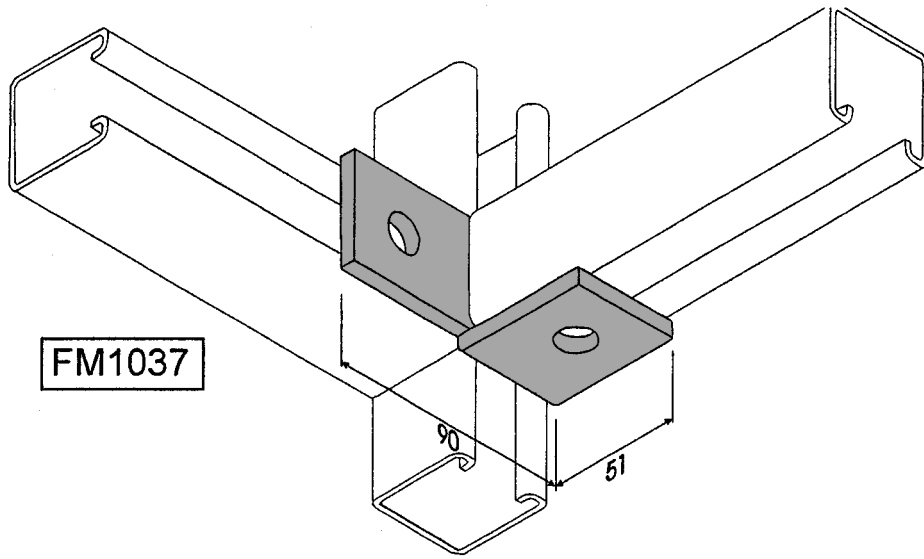

FM1037

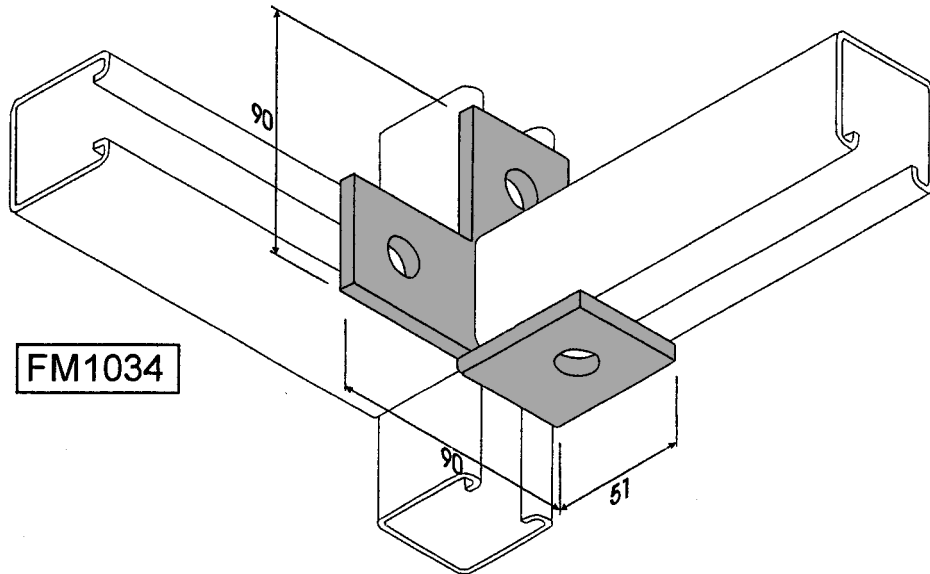

FM1034

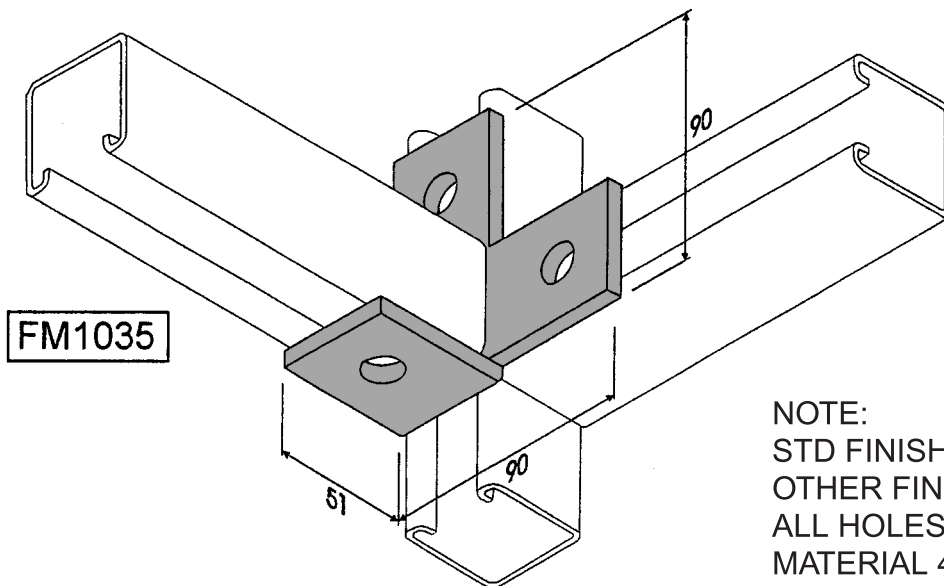

FM1035

NOTE:
STD FINISH H.D.G
OTHER FINISHES AVAIL.
ALL HOLES 14mm
MATERIAL 40 x 6
(U.N.O)

'Z' SHAPE FITTINGS

FM1045
FM1453
FM1736
FM4045
FM5545

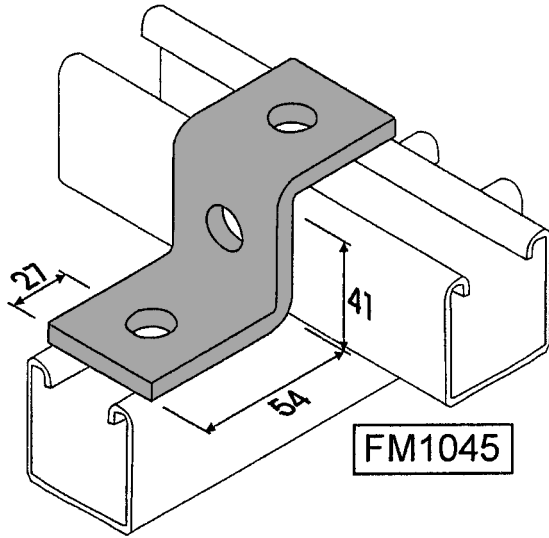

FM1045

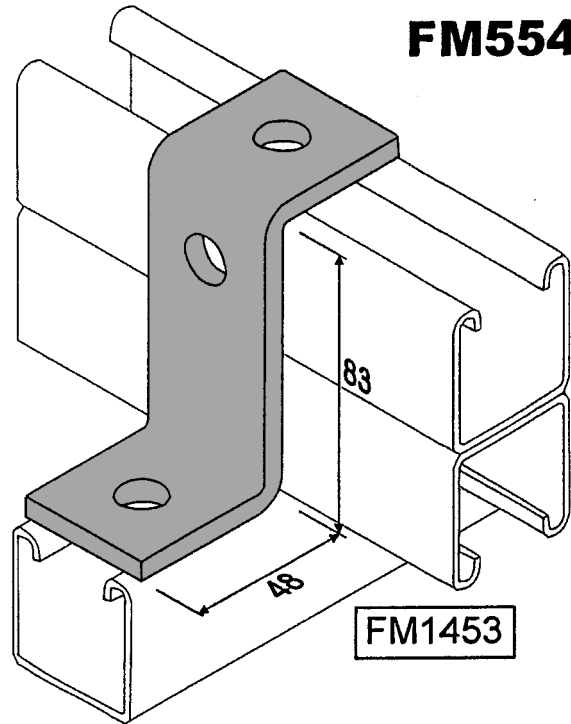

FM1453

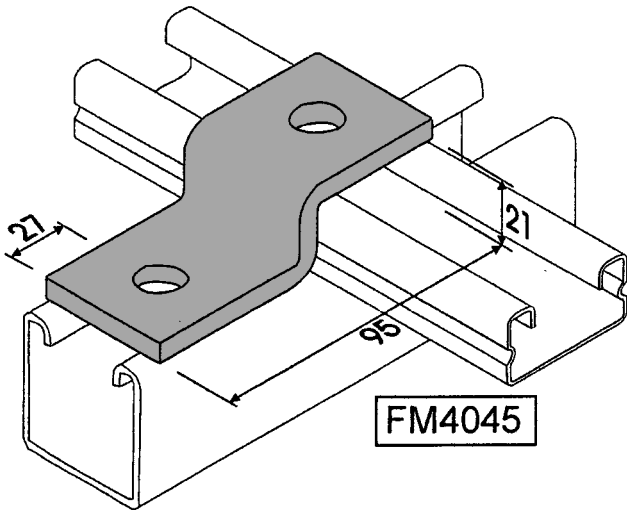

FM4045

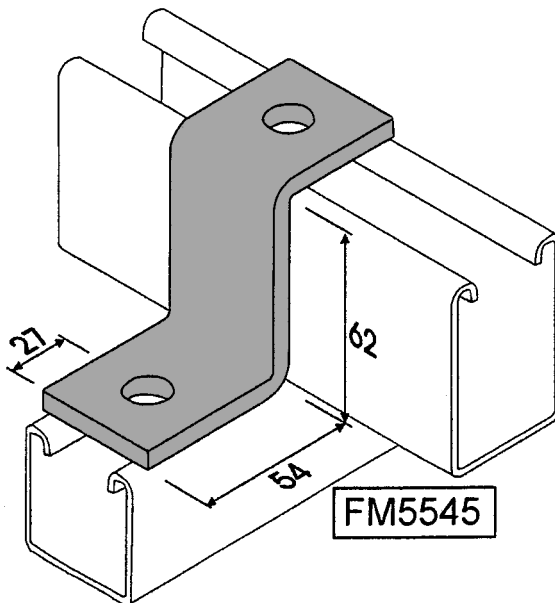

FM5545

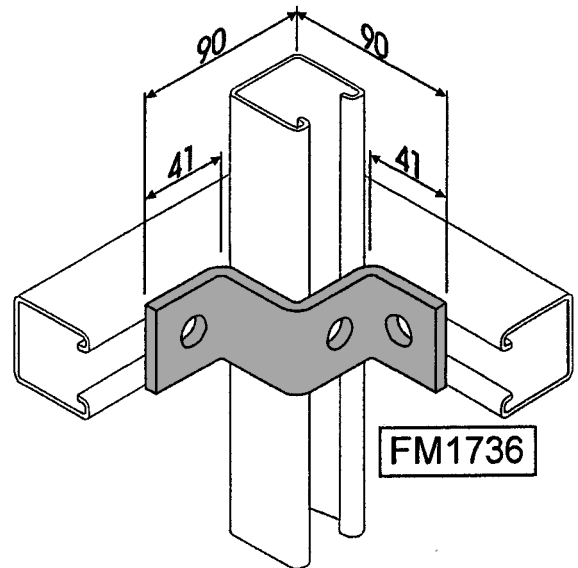

FM1736

NOTE:
STD FINISH H.D.G
OTHER FINISHES AVAIL.
ALL HOLES 14mm
MATERIAL 40 x 6
(U.N.O)

'U' SHAPE FITTINGS

FM1044
FM1047
FM4047
FM5547

Channel Accessories
 & Beam Clamps

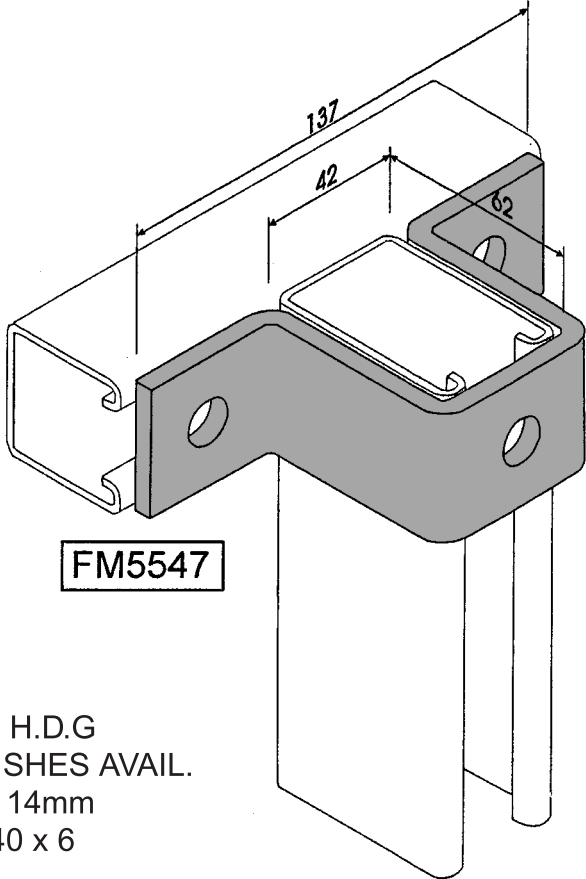
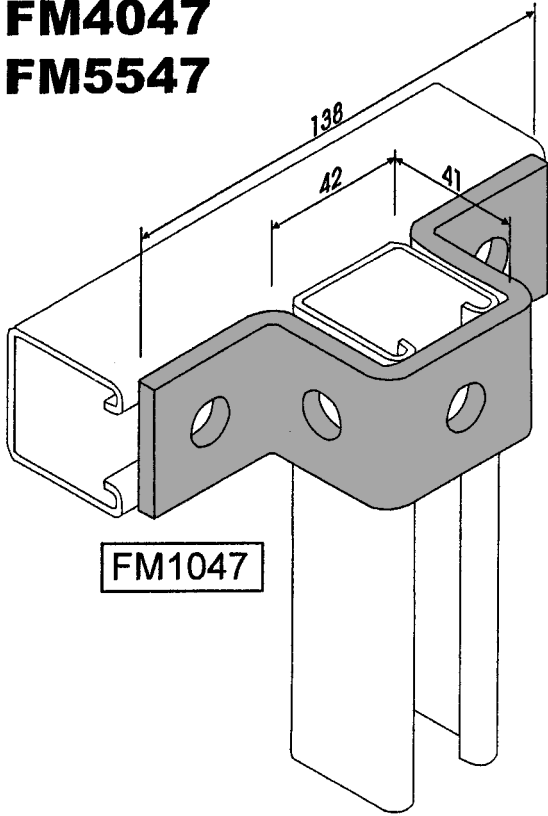

NOTE:
 STD FINISH H.D.G
 OTHER FINISHES AVAIL.
 ALL HOLES 14mm
 MATERIAL 40 x 6
 (U.N.O)

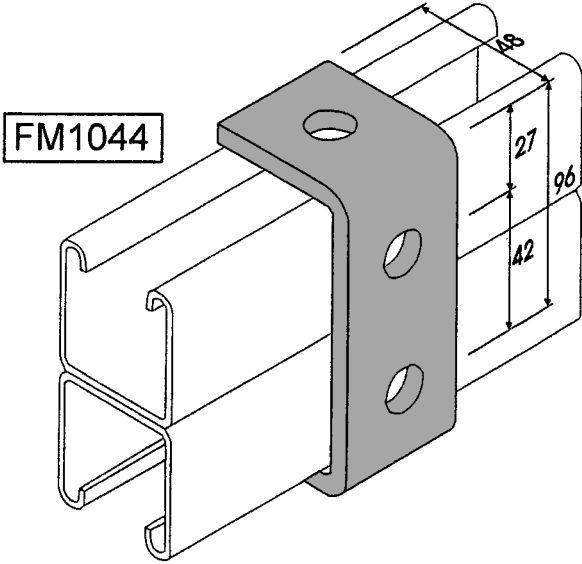
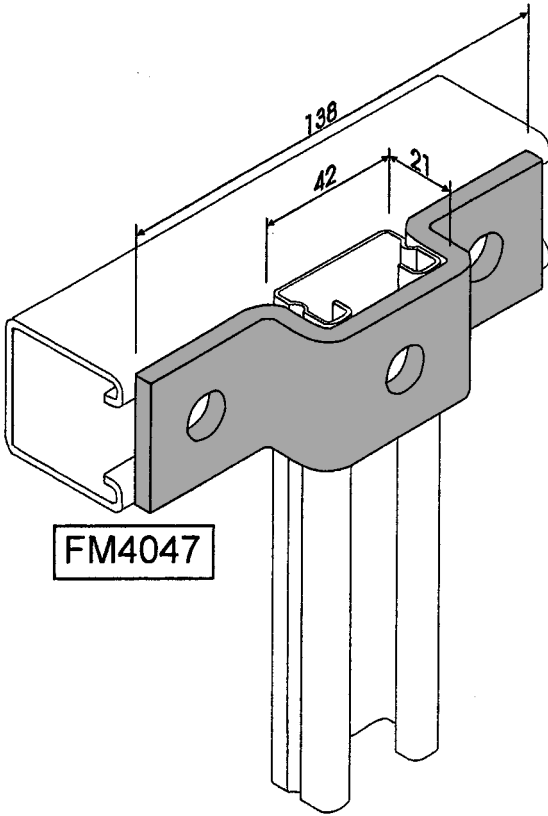

'U' SHAPE FITTINGS

FM1046
FM1376
FM1377
FM1834
FM1834A
FM4376

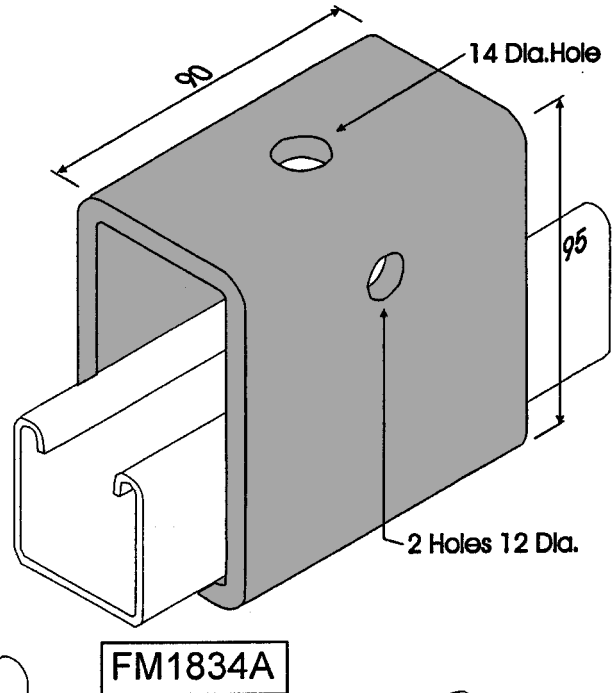
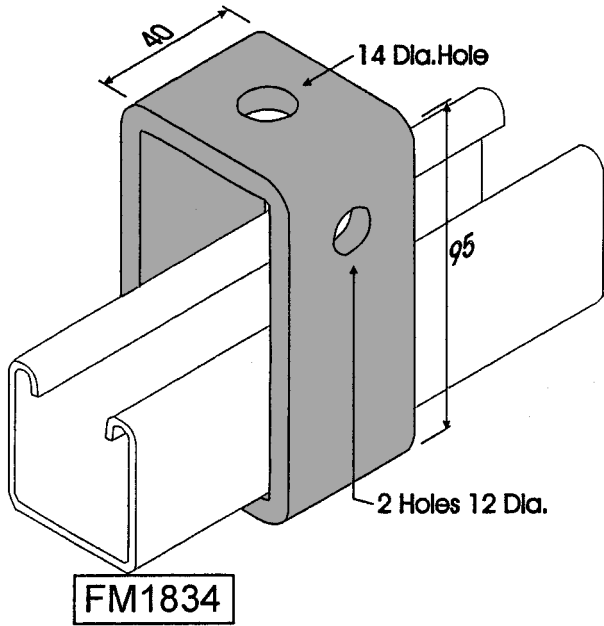

NOTE:
 STD FINISH H.D.G
 OTHER FINISHES AVAIL.
 ALL HOLES 14mm
 MATERIAL 40 x 6
 (U.N.O)

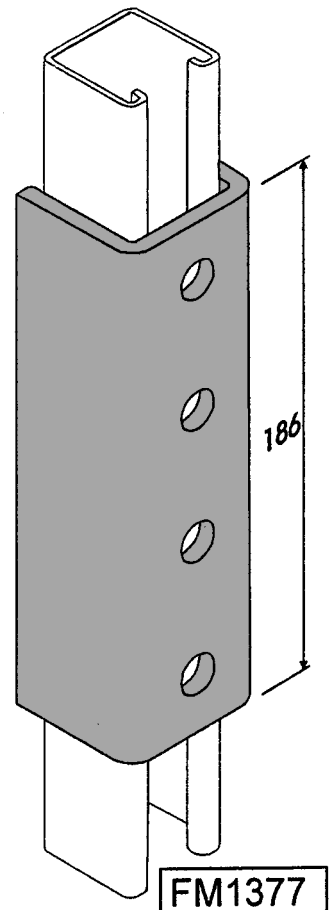
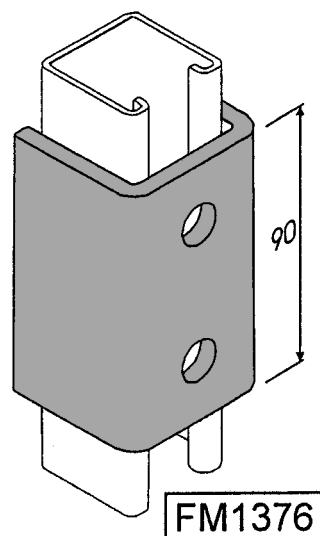
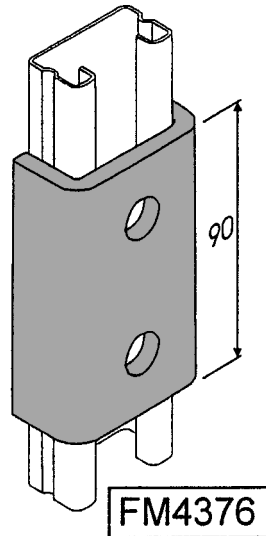
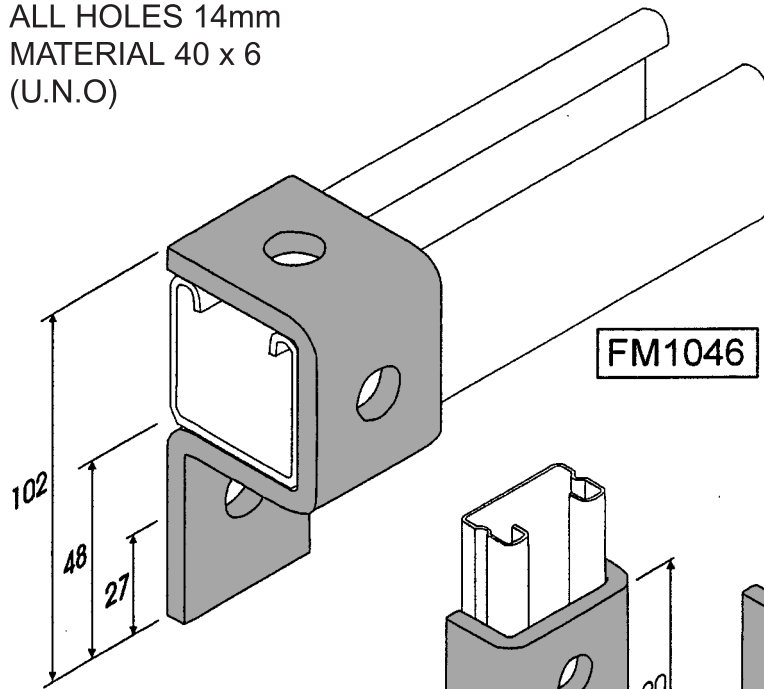

WING SHAPE FITTINGS

FM2223
FM2224
FM2228
FM2346

Channel Accessories
& Beam Clamps

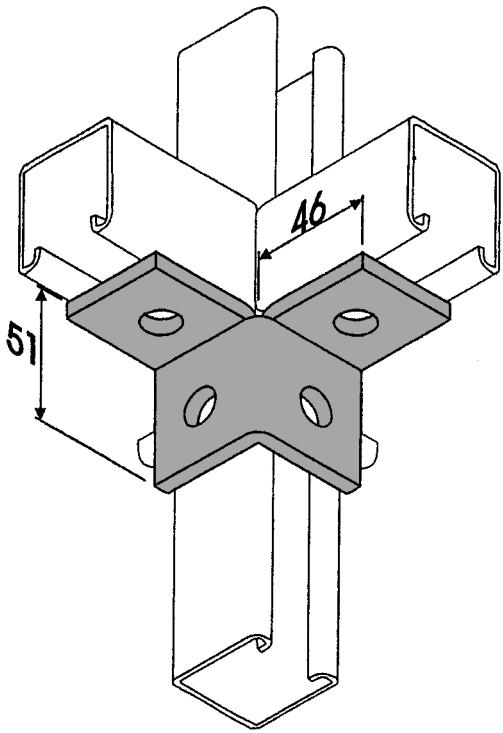

FM2223

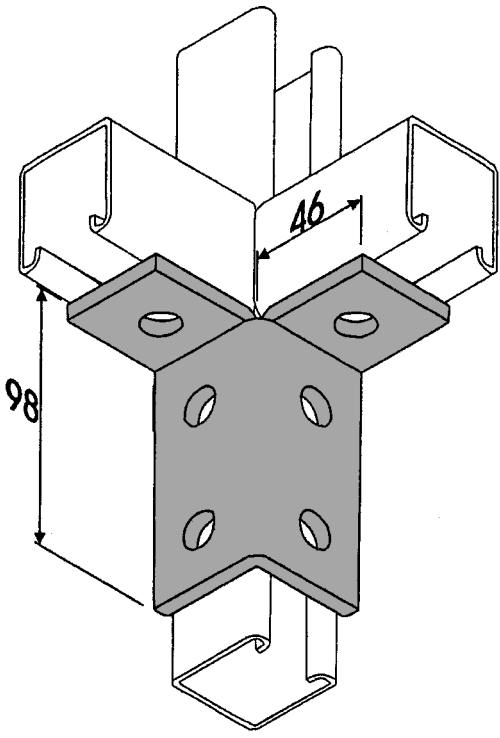

FM2224

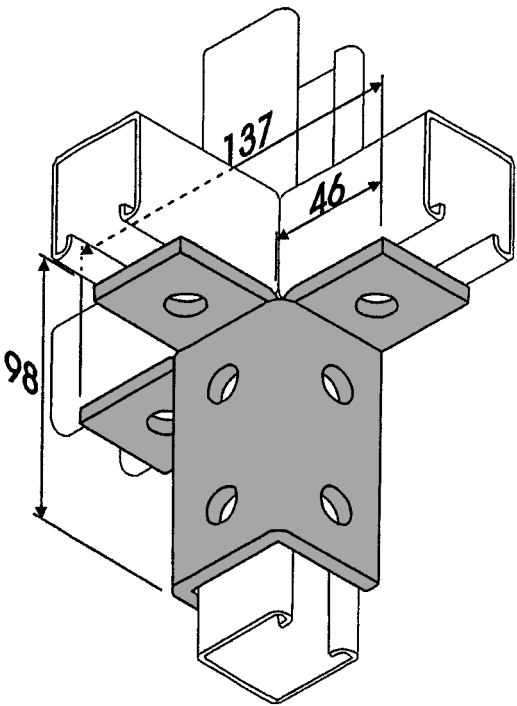

FM2228

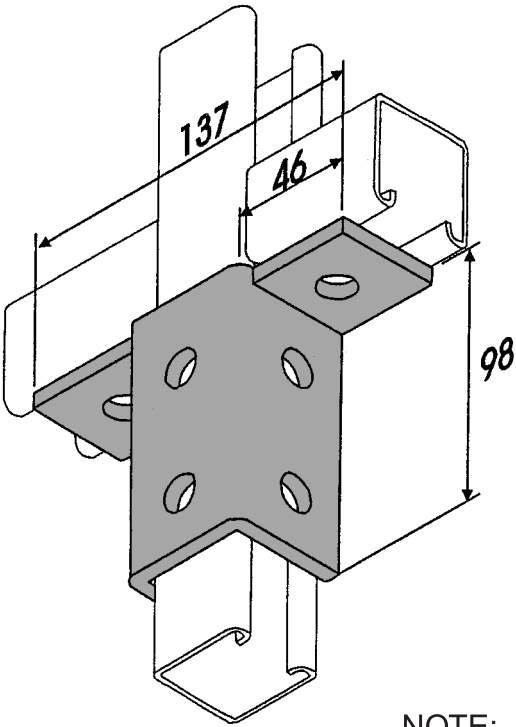

FM2346

NOTE:
STD FINISH H.D.G
OTHER FINISHES AVAIL.
ALL HOLES 14mm
MATERIAL 40 x 6
(U.N.O)

FLAT PLATE FITTINGS

FM1064
FM1065
FM1066
FM1067
FM1941

Part No. 'H'
FM1062 - 9
FM1063 - 11
FM1064 - 14
FM1964 - 18

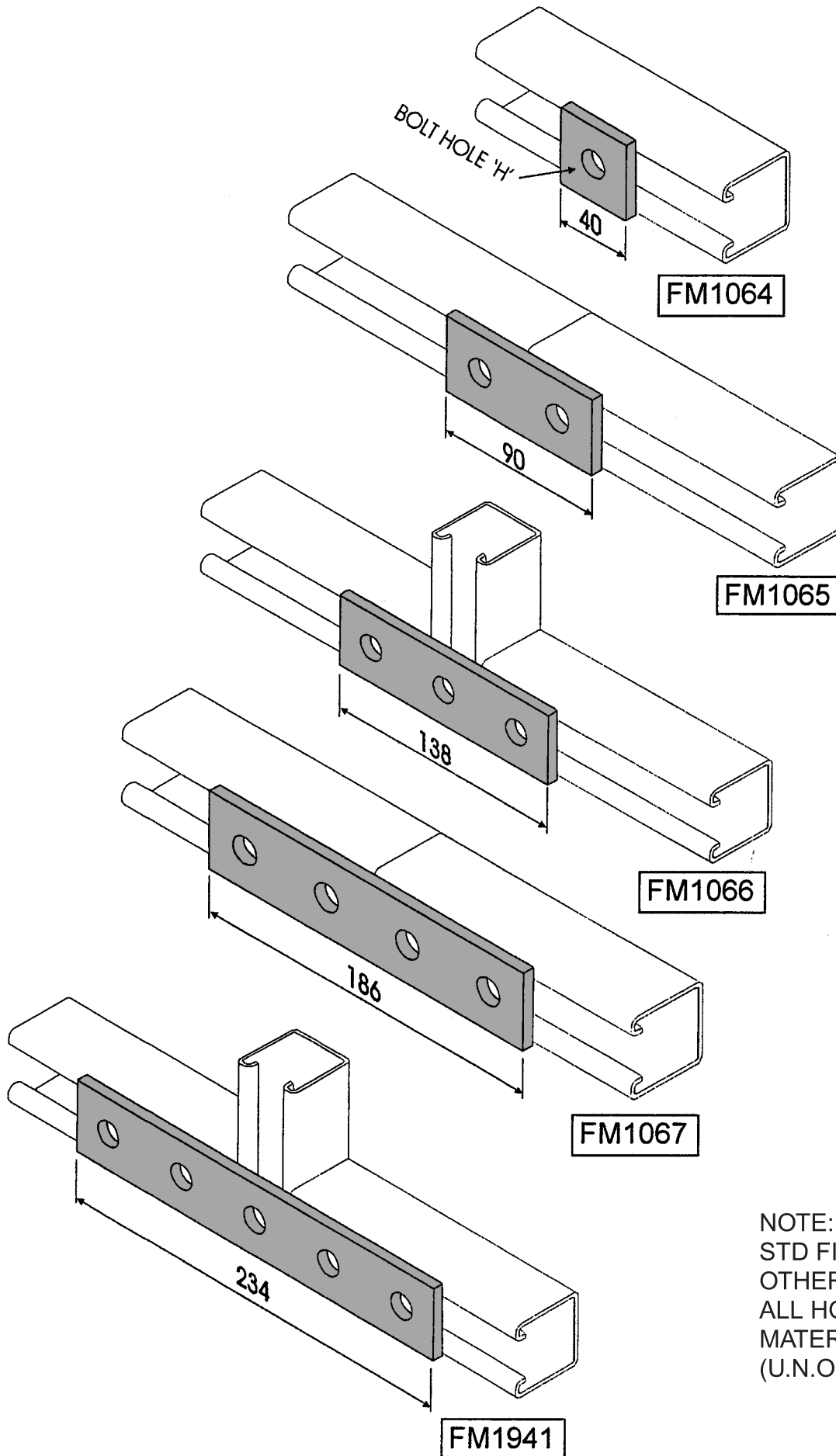

NOTE:
STD FINISH H.D.G
OTHER FINISHES AVAIL.
ALL HOLES 14mm
MATERIAL 40 x 6
(U.N.O)

BASE PLATES

FM2072A
FM2072S1
FM2073
FM2073A-H

Channel Accessories
 & Beam Clamps

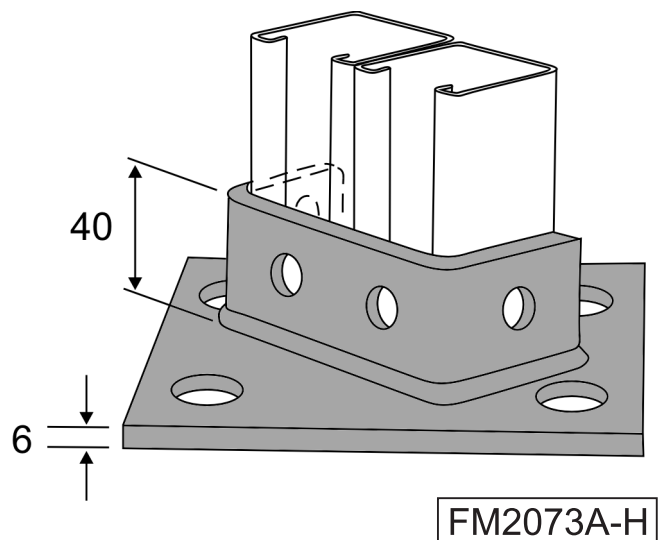
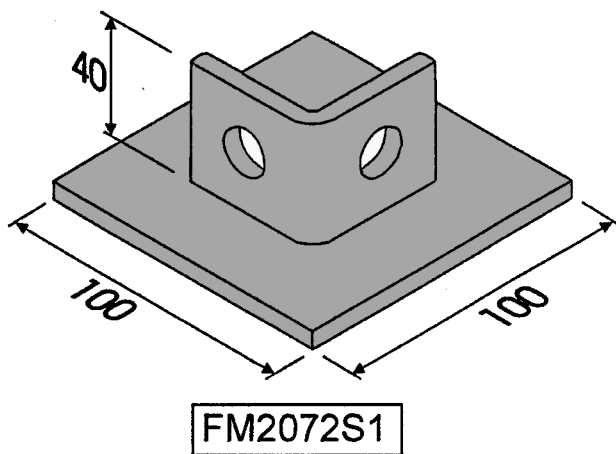
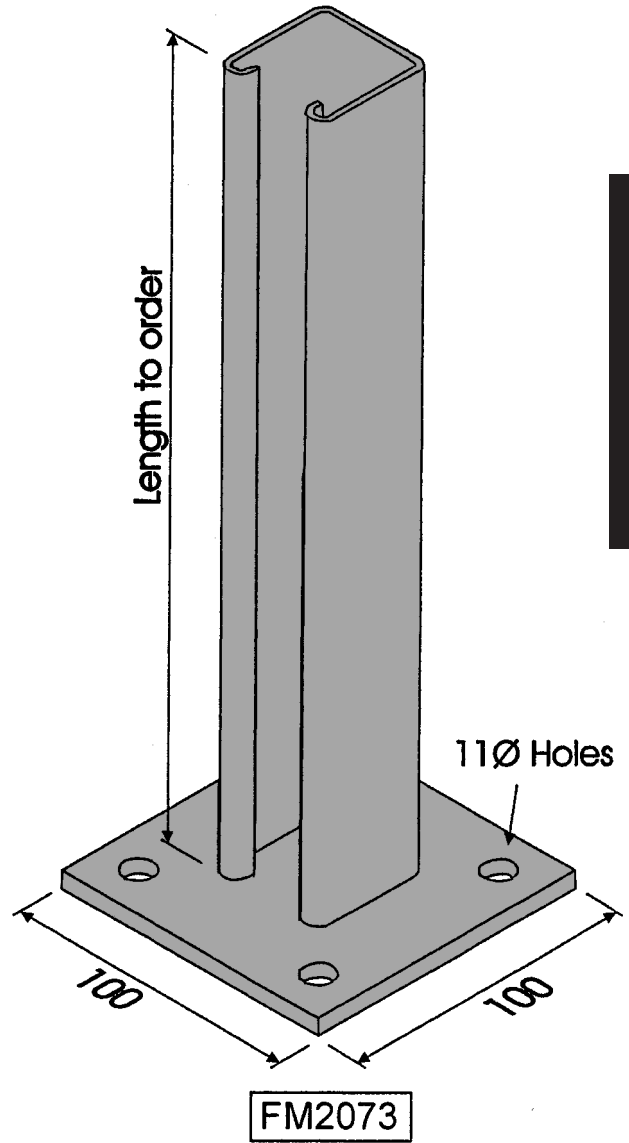
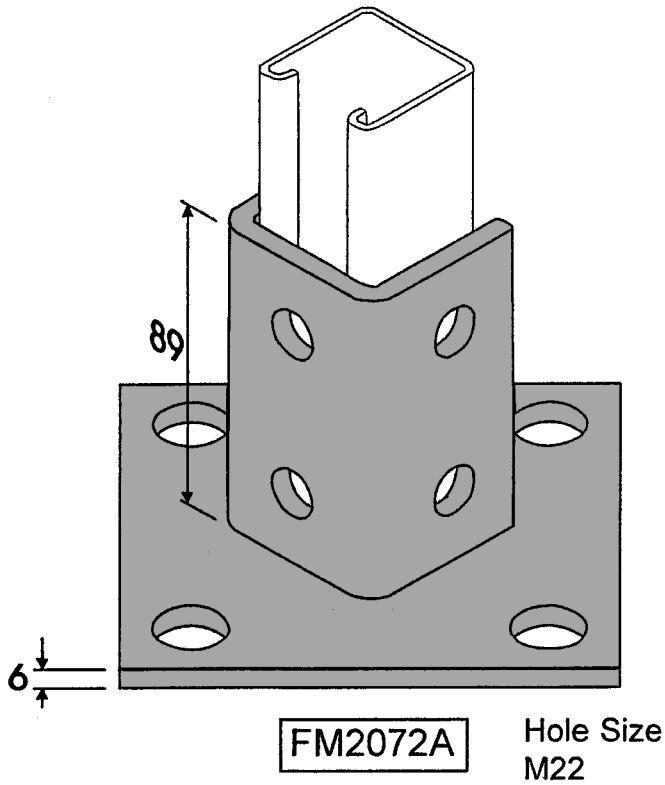

NOTE:
 STD FINISH H.D.G
 OTHER FINISHES AVAIL.
 ALL HOLES 14mm
 MATERIAL 40 x 6
 (U.N.O)

ANGULAR FITTINGS

FM1546

FM2095

FM2097

FM2101

FM2103

FM2106

FM2108

FM1186

FM2452

ANGULAR FITTINGS

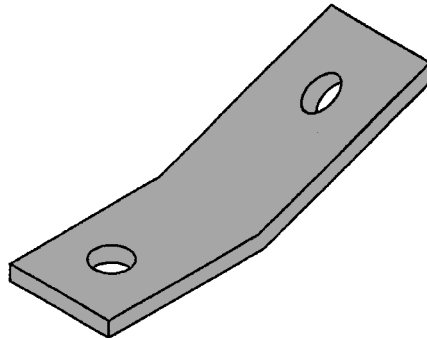
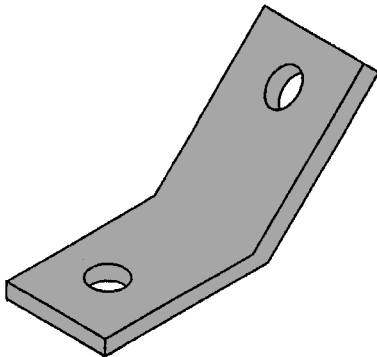

PART NO.	A	B	C
FM2095	75°	91	43
FM2097	60°	86	48
FM1546	45°	76	60

PART NO.	A	B
FM2101	30°	83
FM2103	15°	84

FM2452

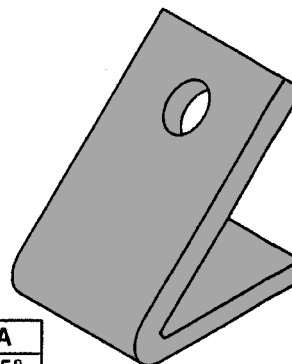
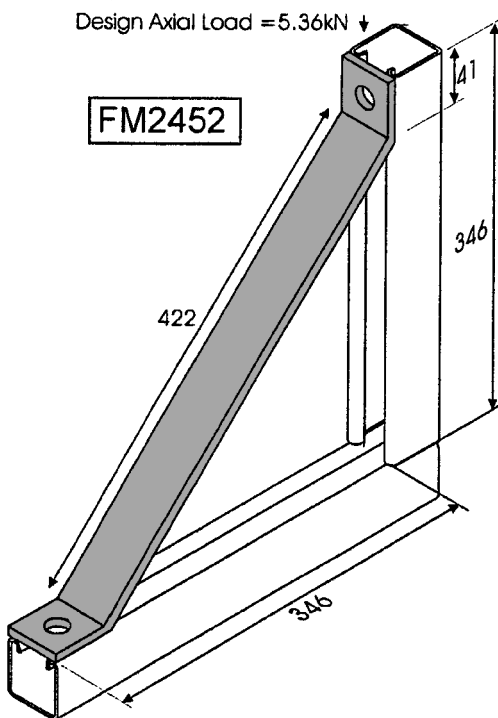
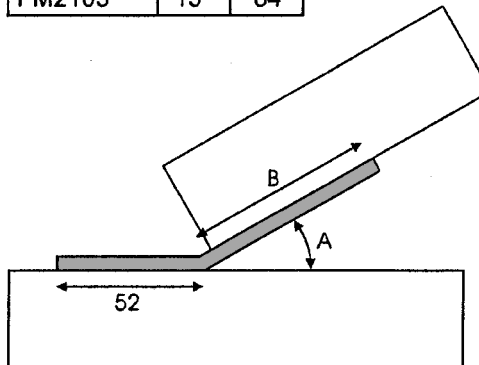
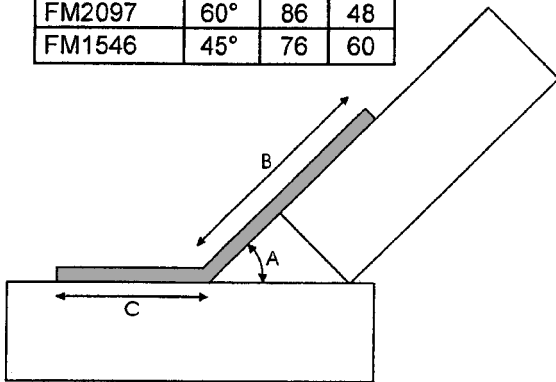

PART NO.	A
FM2106	75°
FM2108	60°
FM1186	45°

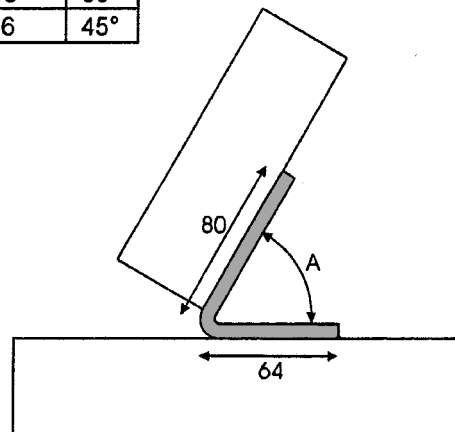

EF1500
EF1510

DURAGAL SLOTTED ANGLE / DURAGAL ANGLE

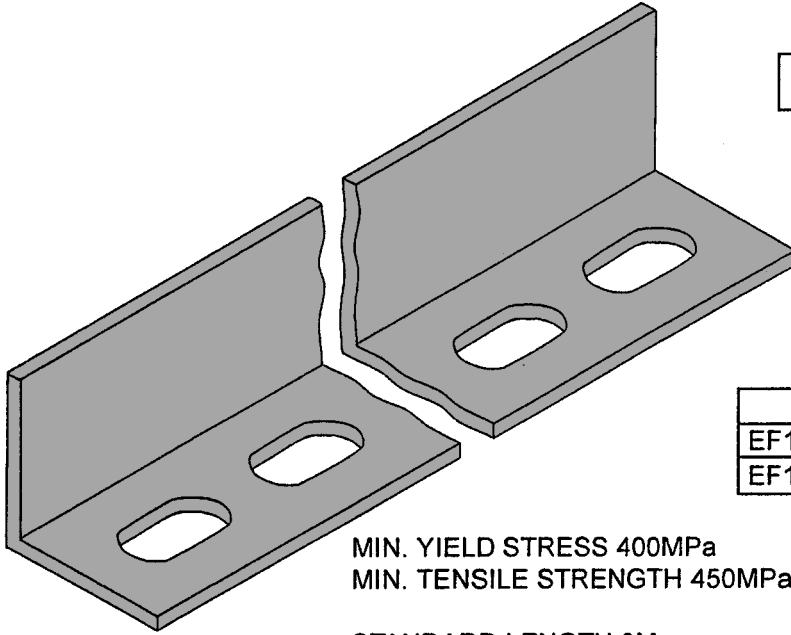

DURAGAL SLOTTED ANGLE

PART NO.	MATERIAL	SLOT
EF1500-030	30x30x2.5	11x18
EF1500-050	50x50x5	14x30

MIN. YIELD STRESS 400MPa
MIN. TENSILE STRENGTH 450MPa

STANDARD LENGTH 3M

FINISH: DURAGAL

Channel Accessories
B Beam Clamps

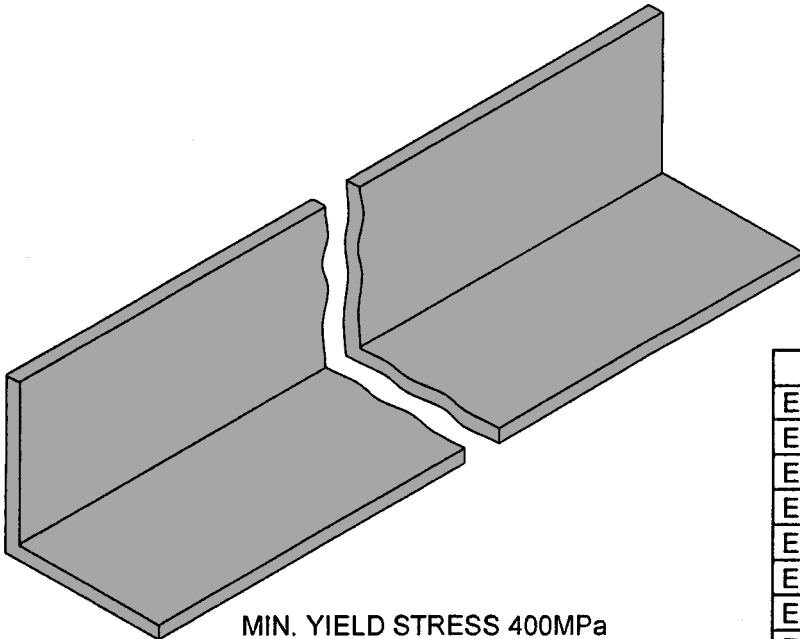

DURAGAL ANGLE

PART NO.	MATERIAL
EF1510-30/2.5	30 x 30 x 2.5
EF1510-40/2.5	40 x 40 x 2.5
EF1510-40/4.0	40 x 40 x 4.0
EF1510-45/2.5	45 x 45 x 2.5
EF1510-45/4.0	45 x 45 x 4.0
EF1510-50/2.5	50 x 50 x 2.5
EF1510-50/4.0	50 x 50 x 4.0
EF1510-50/5.0	50 x 50 x 5.0
EF1510-65/4.0	65 x 65 x 4.0
EF1510-65/5.0	65 x 65 x 5.0
EF1510-75/4.0	75 x 75 x 4.0
EF1510-75/5.0	75 x 75 x 5.0

MIN. YIELD STRESS 400MPa
MIN. TENSILE STRENGTH 450MPa

STANDARD LENGTH 6M

FINISH: DURAGAL

BEAM CLAMPS / PURLIN CLIPS

**EF1600
EF1700
EF1750
EF1900
EF2000
EF14-TI**

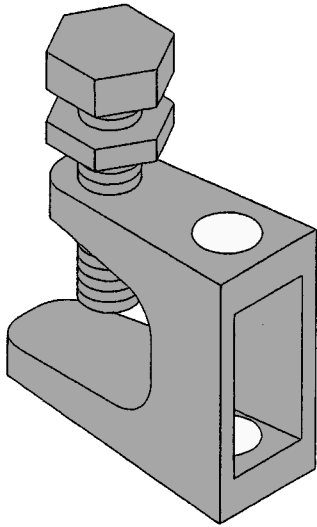

EF1600 BEAM CLAMP	
PART NO	ROD DIA.
EF1600-M8	M8
EF1600-M10	M10
EF1600-M12	M12
EF1600-M16	M16

FINISH: ZINC PLATED

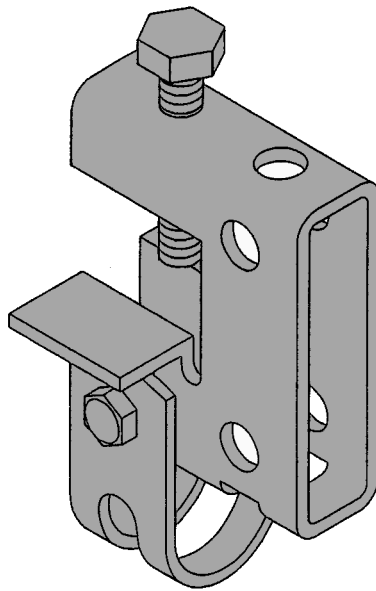

EF1700 BEAM CLAMP	
PART NO	ROD DIA.
EF1700-M10	M10

FINISH: ZINC PLATED

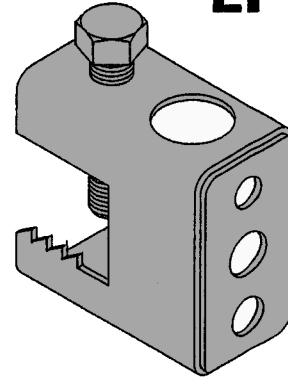

EF1750 L.D. BEAM CLAMP	
PART NO	ROD DIA.
EF1750-M10	M10

FINISH: ZINC PLATED

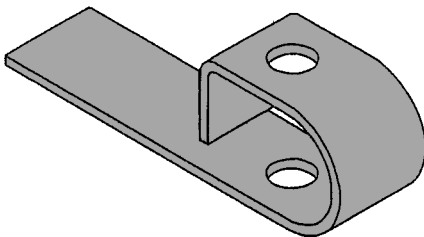

EF1900 PURLIN CLIP	
PART NO	ROD DIA.
EF1900-M8	M8
EF1900-M10	M10
EF1900-M12	M12

FINISH: ZINC PLATED

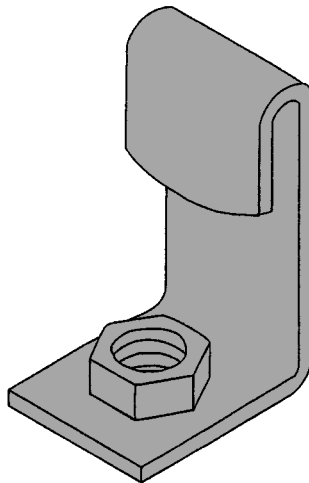

EF2000 PURLIN CLIP	
PART NO	ROD DIA.
EF2000-M8	M8
EF2000-M10	M10
EF2000-M12	M12

FINISH: ZINC PLATED

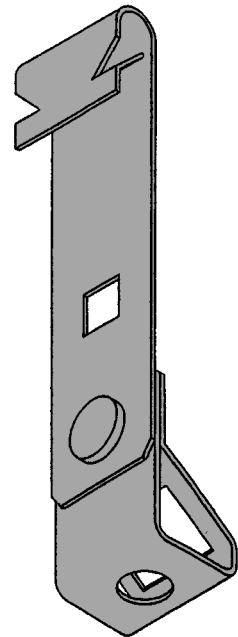

EF14-TI PURLIN CLIP	
PART NO	ROD DIA.
EF14M6-TI	M6
EF14M8-TI	M8
EF14M10-TI	M10

FINISH: ZINC PLATED

FM171
FM172
FM173
FM174

BEAM CLAMPS FOR METAL FRAMING CHANNEL

Channel Accessories
8 Beam Clamps

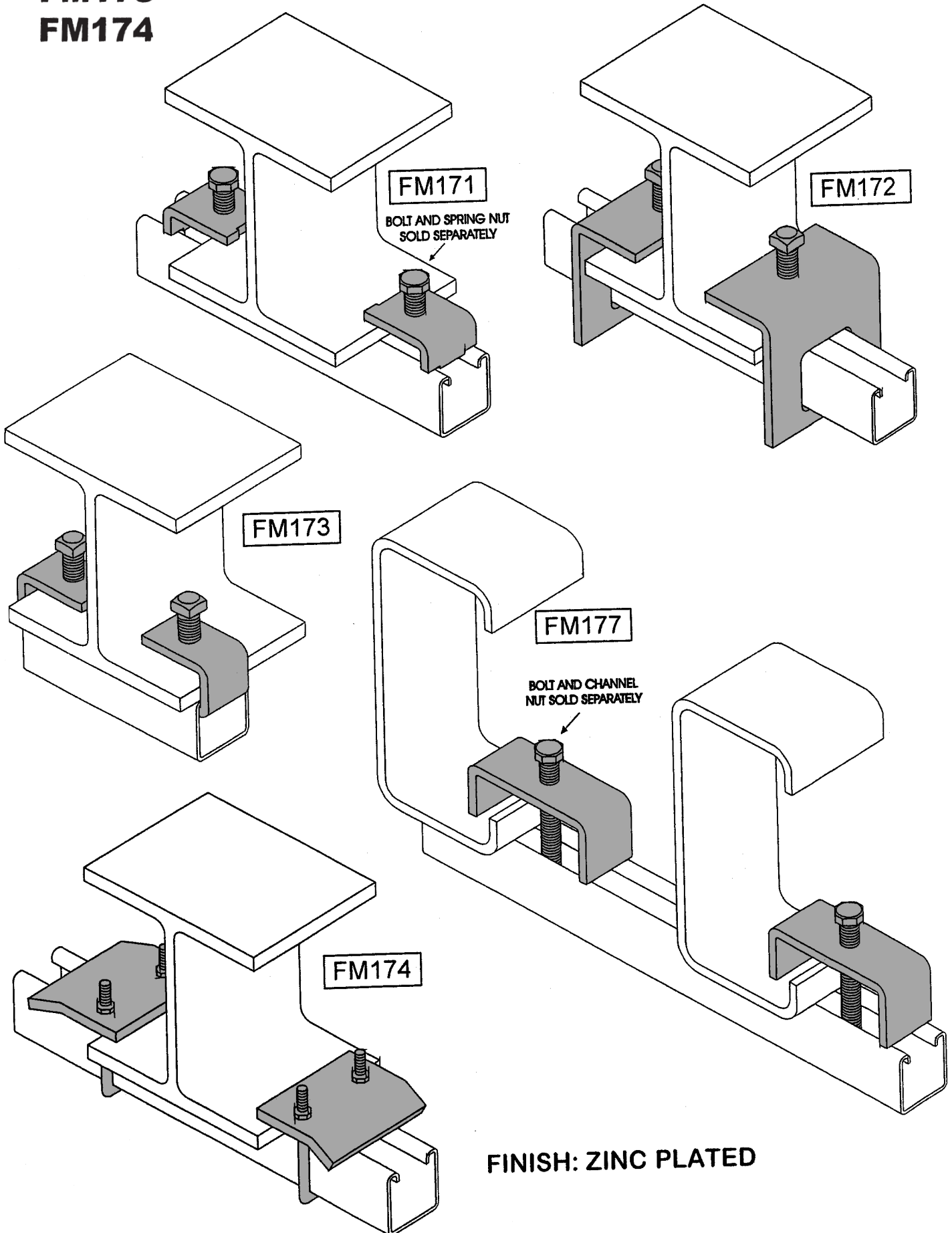

FINISH: ZINC PLATED

BEAM ATTACHMENTS

FM180
FM181
FM182

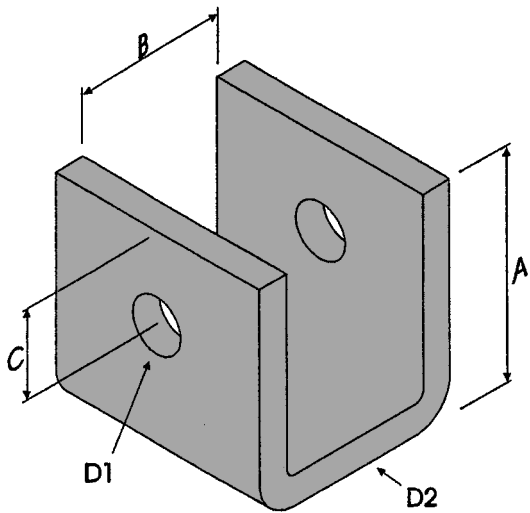

FM180 WELDED BEAM HANGER						
PART NO.	A	B	C	D1	D2	W x T
FM180-10	75	32	20	14	11	50 x 10
FM180-12	75	32	20	14	14	50 x 10
FM180-16	75	50	30	18	18	75 x 10
FM180-20	90	50	30	22	22	75 x 10
FM180-24	125	50	40	26	26	100 x 12

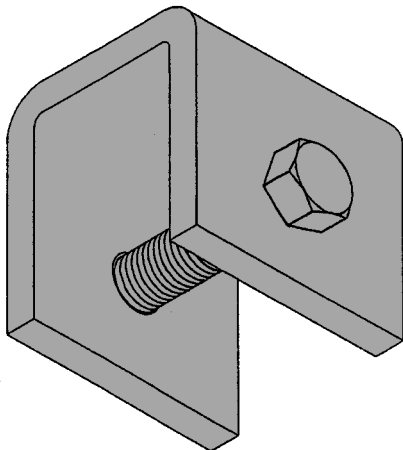

FM181 WELDED BEAM HANGER						
PART NO.	A	B	C	D1	D2	W x T
FM181-10	75	32	20	14	11	50 x 10
FM181-12	75	32	20	14	14	50 x 10
FM181-16	75	50	30	18	18	75 x 10
FM181-20	90	50	30	22	22	75 x 10
FM181-24	125	50	40	26	26	100 x 12

FM182 HANGER STIRRUP							
PART NO.	A	B	C	D	D1	D2	W x T
FM182-10	60	40	30	15	11	11	32 x 5
FM182-12	60	40	40	20	14	14	40 x 6
FM182-16	90	40	40	20	14	18	40 x 6
FM182-20	90	65	50	30	18	22	50 x 10
FM182-24	90	65	50	30	22	26	65 x 10

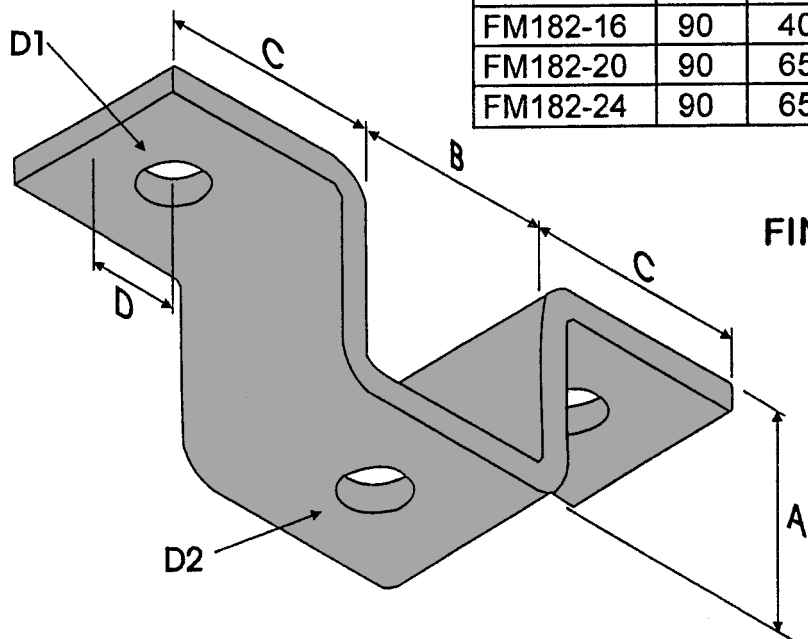

FINISH: PLAIN OR GALVANISED

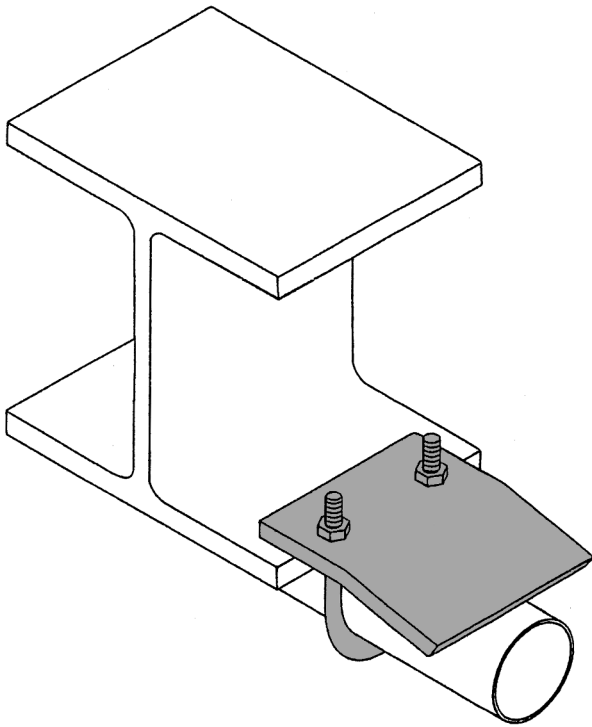

EF700 / EF700LD PIPE BEAM CLIP		
PART NO	PIPE DIA.	U BOLT
EF700LD	25nb to 50nb	M6
EF700	25nb to 50nb	M10

FINISH: ZINC PLATED
'U' Bolt to be ordered separately.
Sizes above 50nb available on request.

FIRE PROTECTION PRODUCTS

EF800
EF900
EF1000
EF1100
EF1200
EF1300
EF1400

BEAM ATTACHMENTS					
BEAM CLAMP			HOOK BOLT		
PART NO.	'A'	'B'	PART NO.	'C'	'D'
EF800-050	50	12	EF900-075	75	12
EF800-100	100	12	EF900-100	100	12
EF800-150	150	12	EF900-135	135	12
			EF900-175	175	12
EF1000-050	50	10	EF1100-075	75	10
EF1000-100	100	10	EF1100-100	100	10
EF1000-150	150	10	EF1100-135	135	10
			EF1100-175	175	10

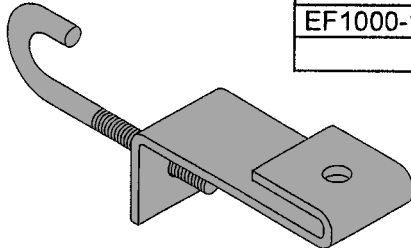
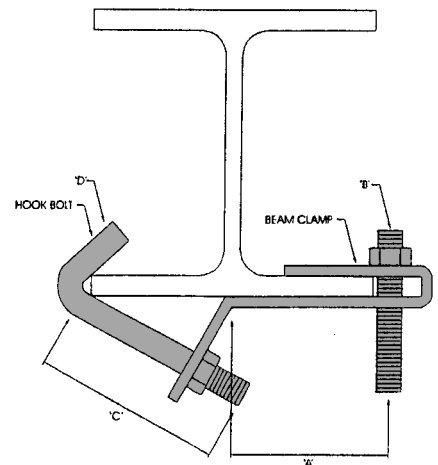

EF1300 ANGLE BRACKET

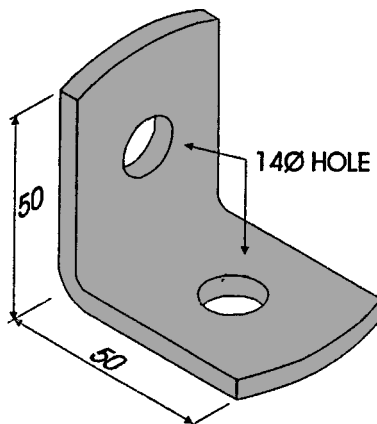

FINISH: ZINC PLATED

EF1200 MOUNTING PLATES

PART NO	THREAD
EF1200A-M10	M10
EF1200A-M12	M12
EF1200B-M10	M10
EF1200B-M12	M12
EF1200C-M10	M10
EF1200C-M12	M12

FINISH: ZINC PLATED

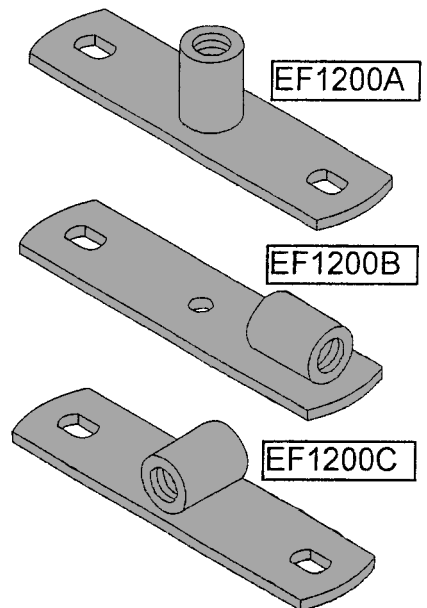

EF1400 PURLIN CLEAT

PART NO	U BOLT DIA.
EF1400-M6	M6
EF1400-M10	M10
EF1400-M12	M12

FINISH: ZINC PLATED

NOTE: U BOLT NOT INCLUDED, ORDER SEPERATELY

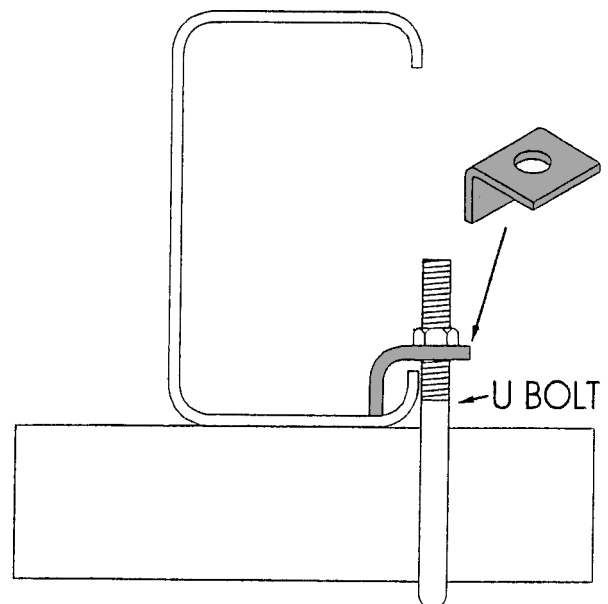

FIRE PROTECTION PRODUCTS

EF2200
EF2300
FM1357 HDG
FM1359 HDG

Channel Accessories
& Beam Clamps

EF2200 PURLIN CLIP H.D.

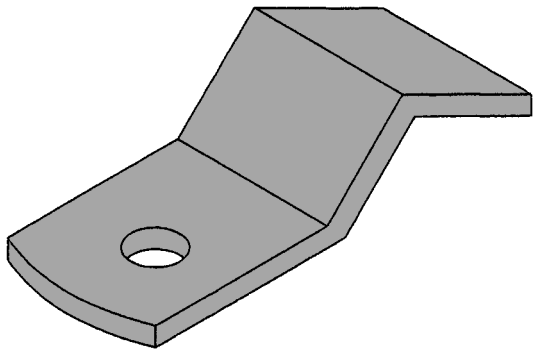

FINISH: ZINC PLATED

EF2300 PURLIN CLIP L.D.

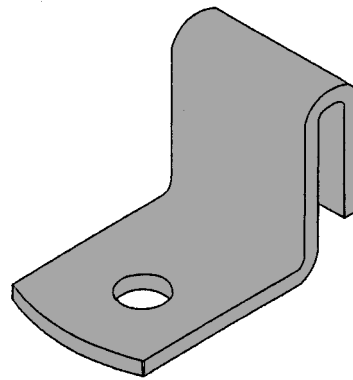

FINISH: GALVABOND

FM1357HDG

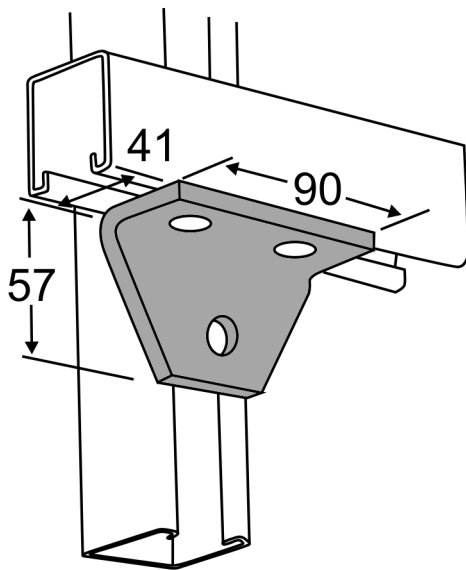

FM1359HDG

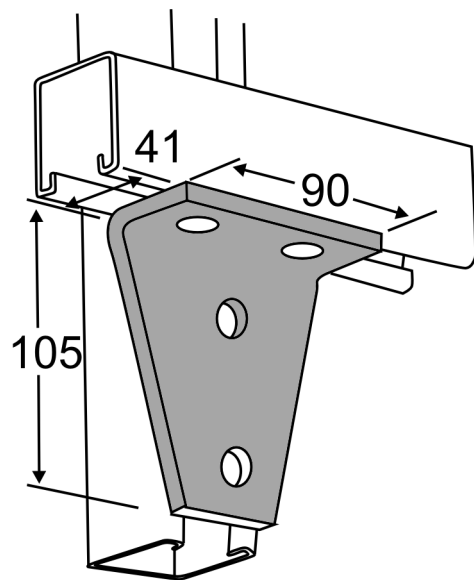

SECTION 3

Fastening Systems & Cantilever Brackets

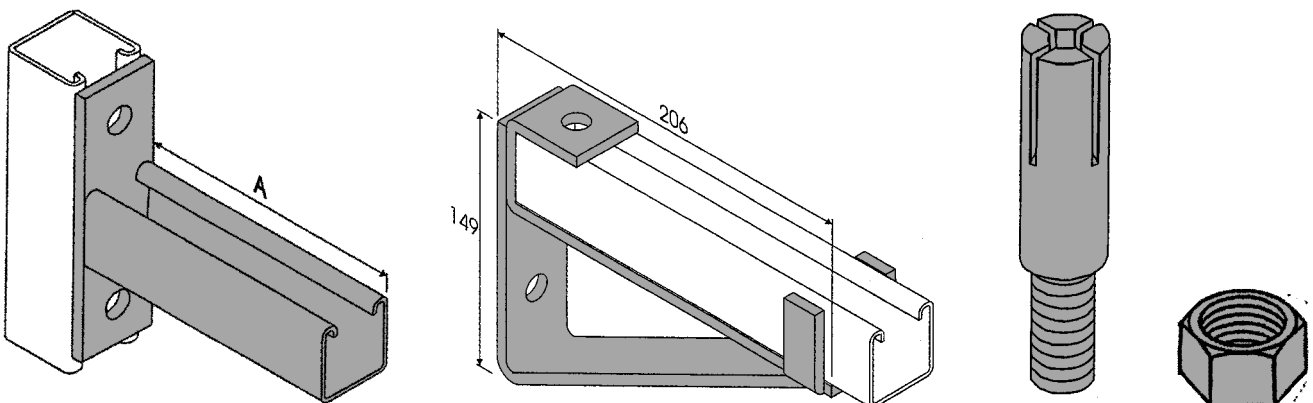

CANTILEVER FITTINGS

FM1075-4
FM1075-8

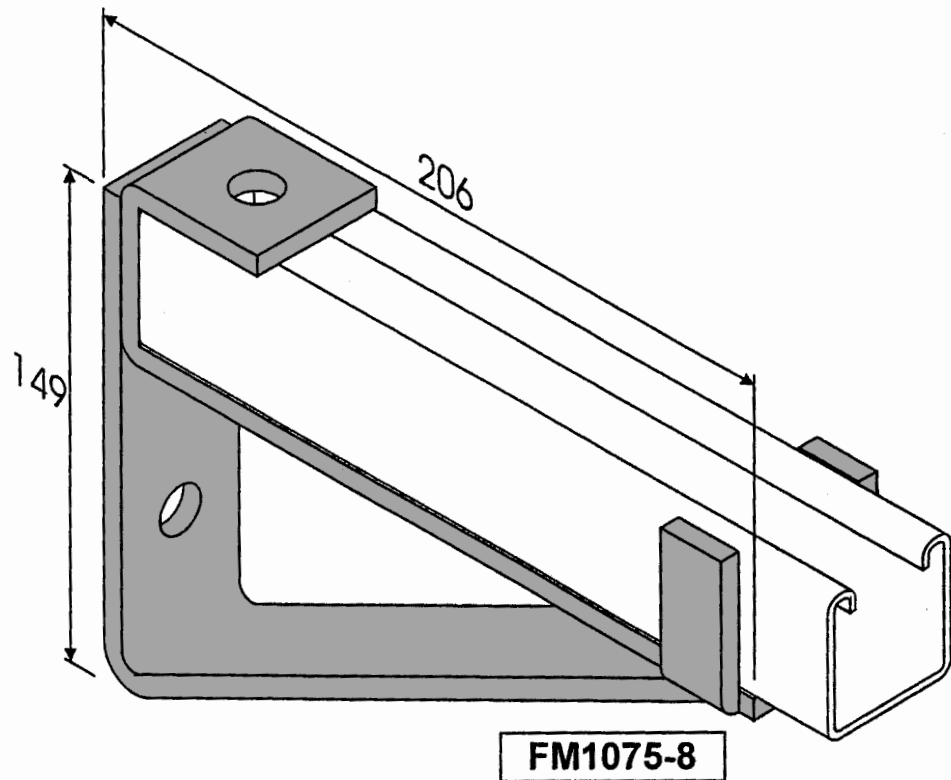
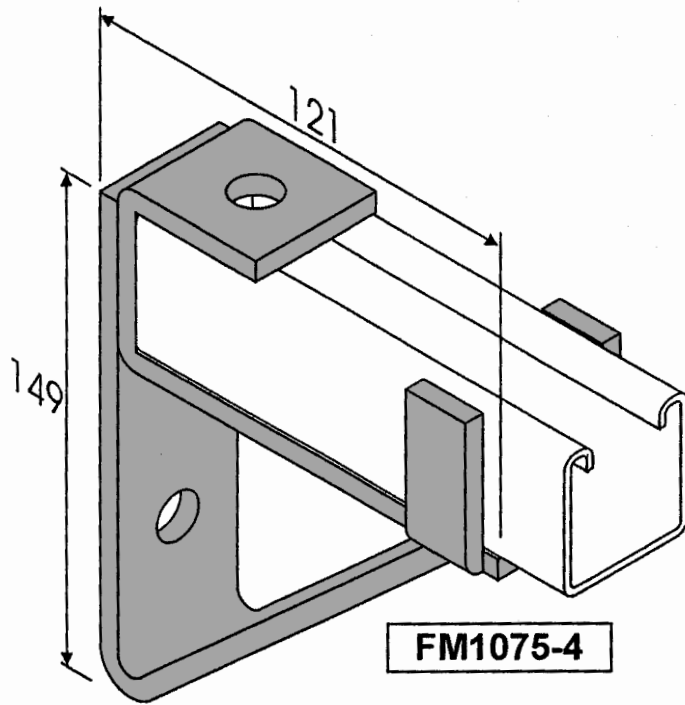

FITS CHANNELS FM1000, FM2000, FM4001

FINISH: GALVANISED

Fastening Systems &
Cantilever Brackets

**EF1800
FM1810
FM1820**

ROD ACCESSORIES

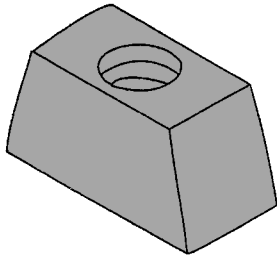

EF1800 WEDGE NUT	
PART NO	ROD DIA.
EF1800-M6	M6
EF1800-M8	M8
EF1800-M10	M10
EF1800-375	3/8" BSW

FINISH: ZINC PLATED

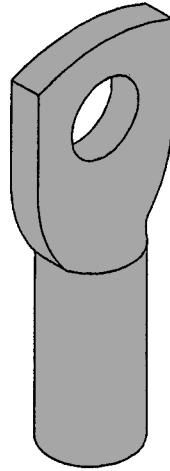

FM1810 EYE NUTS	
PART NO	ROD DIA.
FM1810-M6	M6
FM1810-M8	M8
FM1810-M10	M10
FM1810-M12	M12
FM1810-M16	M16
FM1810-M20	M20

FINISH: ZINC PLATED

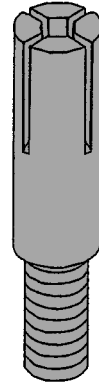

FM1820 DYNASETS	
PART NO	ROD DIA.
FM1820-M6	M6
FM1820-M8	M8
FM1820-M10	M10
FM1820-M12	M12
FM1820-M16	M16
FM1820-M20	M20

FINISH: ZINC PLATED

CANTILEVER BRACKETS

FM155
FM156
FM157
FM158

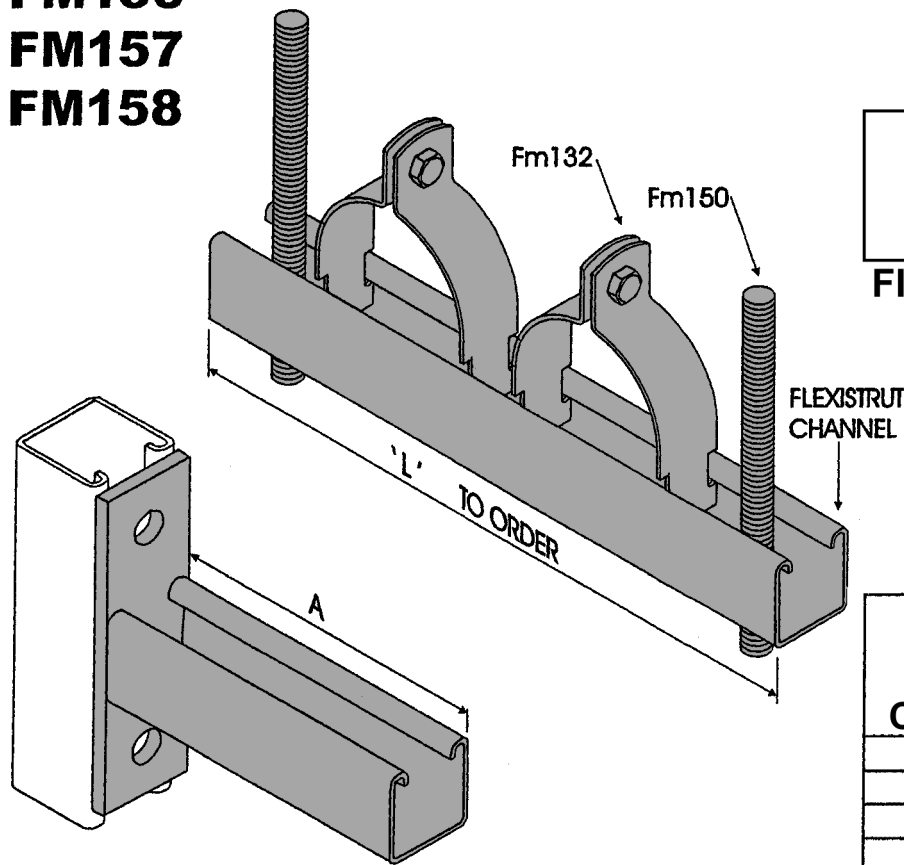

FM155
PIPE & CABLE
CHANNEL TRAPEZE
FINISH: GALVANISED

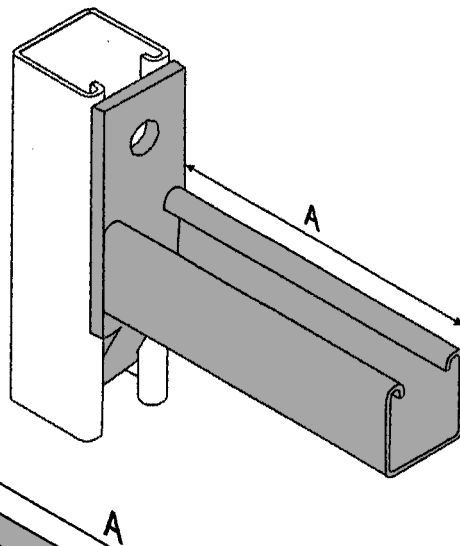

FM156
PIPE & CABLE
CANTILEVER BRACKET

PART NO.	A
FM156-150	150
FM156-300	300
FM156-450	450
FM156-600	600
FM156-700	700

FINISH: GALVANISED

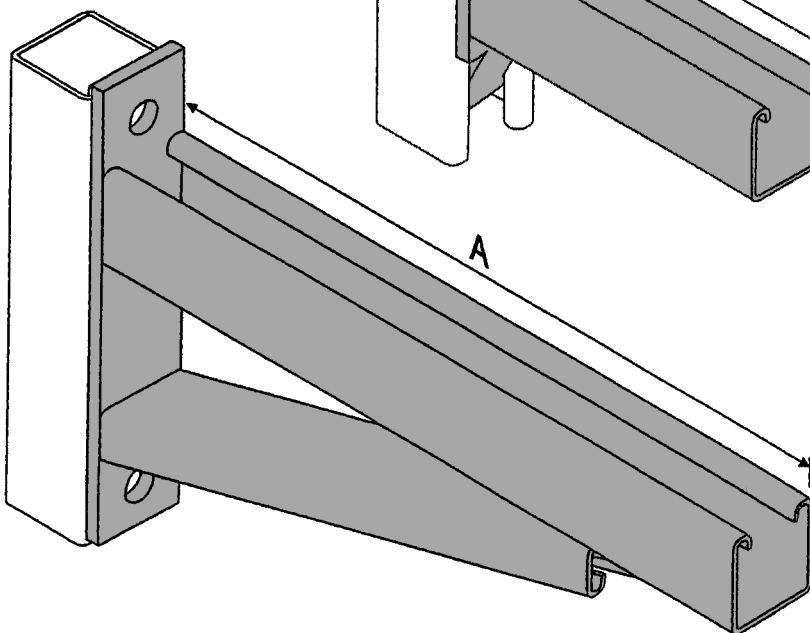

FM157
PIPE & CABLE
CANTILEVER BRACKET

PART NO.	A
FM157-150	150
FM157-300	300
FM157-450	450
FM157-600	600

FINISH: GALVANISED

FM158
PIPE & CABLE
CANTILEVER BRACKET

PART NO.	A
FM158-150	150
FM158-300	300
FM158-450	450
FM158-600	600
FM158-780	780

FINISH: GALVANISED

Fastening Systems &
Cantilever Brackets

FM101

METAL FRAMING CHANNEL THREADED ROD CUTTER

NEW

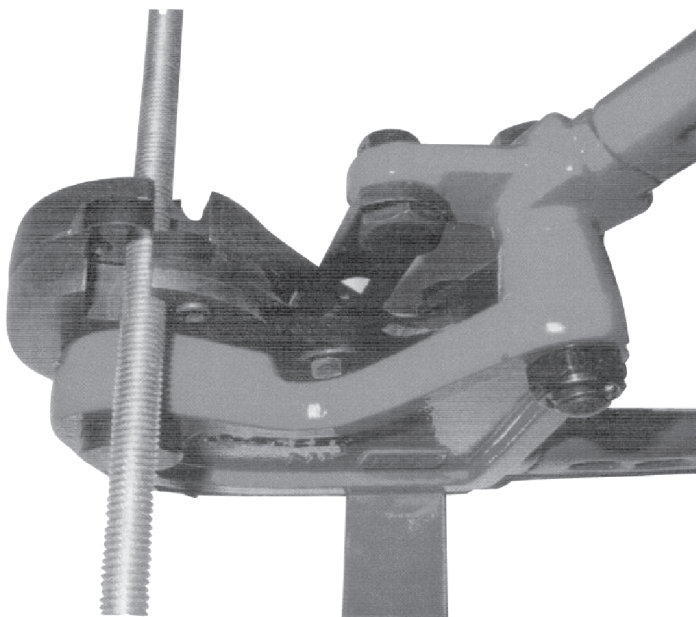
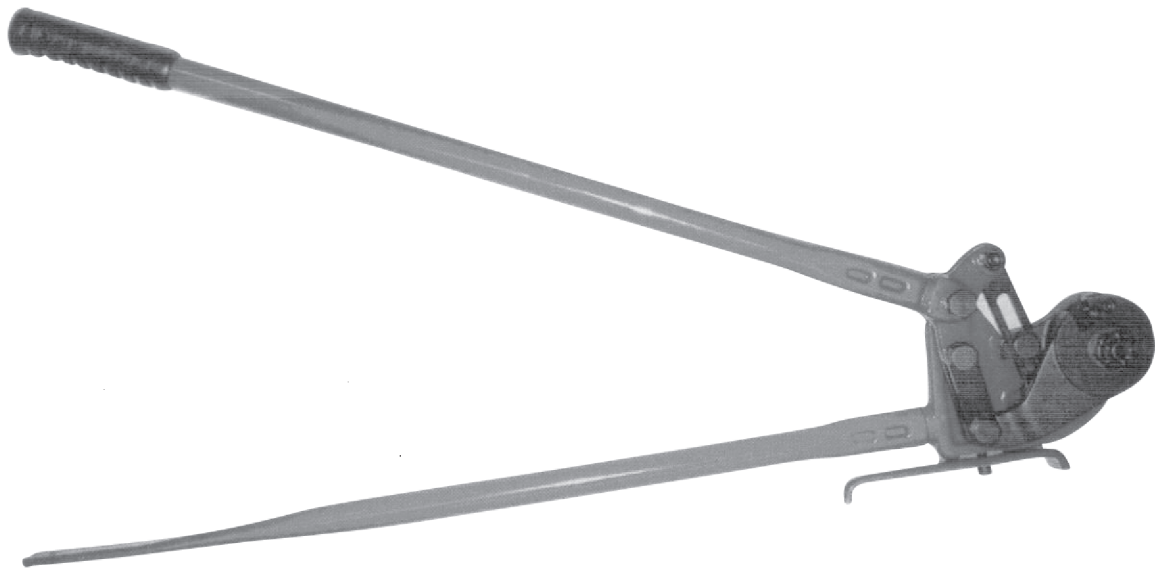

- Cuts threaded rod with little effort.
- Thread not damaged after cutting.
- No burr removal required, enabling immediate use of Allthread.
- Light Weight and Compact at 4.5kg, 760mm long.
- Cutting components made from heat treated alloy steel for sharpness and durability.
- Suitable for 8mm and 10mm rod.

12 mm Blades Now Available

TROLLEY ASSEMBLIES

FM2749
FM2750
FM2751
FM2950

FM2749

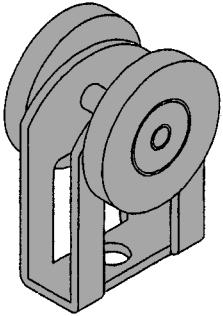

FM2751

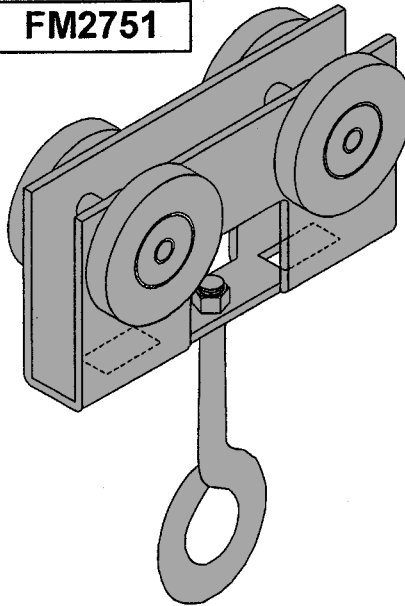

FM2950

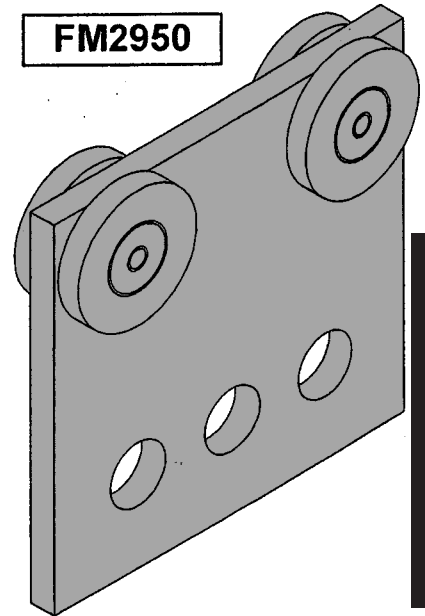

FM2750

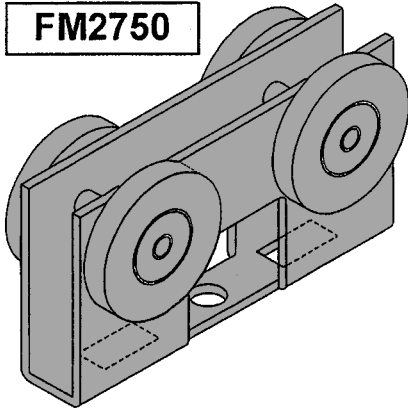

Fastening Systems &
 Cantilever Brackets

NUTS, BOLTS, WASHERS, ETC...

HEX NUTS M6 to M36



CONE POINT SET SCREWS M10, M12

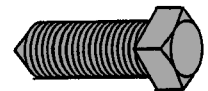

STANDARD WASHER M6 to M36



PAN HEAD SCREWS M6 to M12

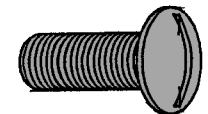

MUDGUARD WASHER M6 to M24



ROD COUPLERS M6 to M20



HEX HEAD SET SCREWS M6 to M20

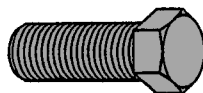

HEX HEAD BOLTS AND NUTS M6 to M36

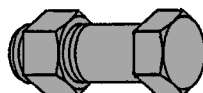

FINISH: ZINC PLATED
OTHER FINISHES INCLUDING GALVANISED AND STAINLESS
STEEL AVAILABLE

METAL FRAMING - NUTS AND BOLTS

Hex Head Set Screws

Part No.	Size	Mass kg/100
HHS0620	M6 x 20	0.6
HHS0625	M6 x 25	0.7
HHS0630	M6 x 30	0.8
HHS0820	M8 x 20	1.2
HHS0825	M8 x 25	1.4
HHS0830	M8 x 30	1.5
HHS0840	M8 x 40	1.8
HHS1020	M10 x 20	1.9
HHS1025	M10 x 25	2.1
HHS1030	M10 x 30	2.5
HHS1040	M10 x 40	3.0
HHS1224	M12 x 24	4.2
HHS1230	M12 x 30	4.5
HHS1240	M12 x 40	5.1
HHS1260	M12 x 60	7.5
HHS1640	M16 x 40	9.5

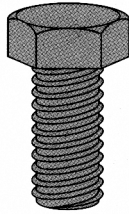

Pan Head Screws

Part No.	Size	Mass kg/100
PHS0620	M6 x 20	0.6
PHS0625	M6 x 25	0.7
PHS0630	M6 x 30	0.8
PHS0825	M8 x 25	1.3

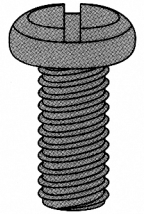

Countersunk Head Screws

Part No.	Size	Mass kg/100
CKS0615	M6 x 15	0.3
CKS0620	M6 x 20	0.4
CKS0820	M8 x 20	0.8
CKS1020	M10 x 20	1.3

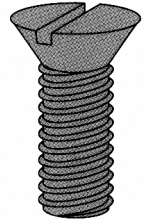

Slotted Hex Head Set Screws

Part No.	Size	Mass kg/100
SHS0620	M6 x 20	0.6
SHS0825	M8 x 25	1.2
SHS0830	M8 x 30	1.3

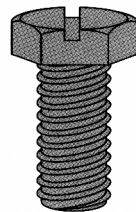

Cone Point Set Screws

Part No.	Size	Mass kg/100
CPS1040	M10 x 40	2.3
CPS1240	M12 x 40	3.8
CPS1250	M12 x 50	4.4

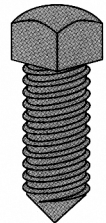

Other sizes of all nuts and bolts and washers available upon request.
 Finishes: Zinc Plated, Hot Dipped Galvanised and Stainless Steel 304/316 grades.

METAL FRAMING - NUTS AND BOLTS

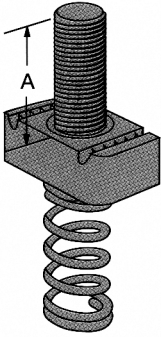

Stud Nut - FM2378M6-1 to P2381M12-5

Part No.	Size	Dim "A"	Mass kg/100
FM2378M6-1	M6	22	3.63
FM2378M6-3	M6	34	4.09
FM2380M10-1	M10	22	5.90
FM2380M10-4	M10	41	6.18
FM2381M12-2	M12	22	6.36
FM2381M12-5	M12	41	8.17

Note: Grooves Serrated.

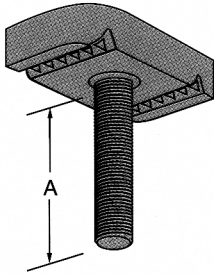

Fixture Stud Nut - P3116

Part No.	Size	Dim "A"	Mass kg/100
FM3116	M6	30	3.50

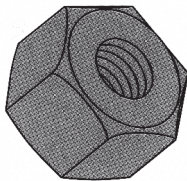

Hexagon Nuts

Part No.	Size	Mass kg/100
HN06	M6	0.2
HN08	M8	0.5
HN10	M10	0.8
HN12	M12	1.8
HN16	M16	3.3
HN20	M20	5.6

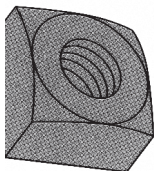

Swivel Nuts

Part No.	Size	Mass kg/100
FM267910	M10	1.7
FM267912	M12	1.5

Fastening Systems & Cantilever Brackets

METAL FRAMING - NUTS AND BOLTS



Flat Washers

Part No.	Size	Mass kg/100
FW06	M6	0.1
FW08	M8	0.1
FW10	M10	0.3
FW12	M12	0.4
FW16	M16	0.8
FW20	M20	0.9



Spring Washers

Part No.	Size	Mass kg/100
SW06	M6	0.1
SW08	M8	0.2
SW10	M10	0.3
SW12	M12	0.4
SW16	M16	0.6
SW20	M20	1.0

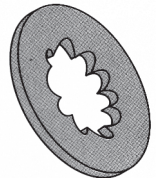

Shakeproof Lock Washers

Part No.	Size	Mass kg/100
LW06	M6	0.05
LW08	M8	0.06
LW10	M10	0.08
LW12	M12	0.10
LW16	M16	0.13
LW20	M20	0.20

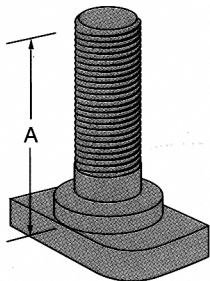

Stud Bolt - FMB045 to FMB102

Part No.	Size	Dim "A"	Mass kg/100
FMB045	M16	45	10.00
FMB076	M16	76	14.00
FMB102	M16	102	18.00

METAL FRAMING - NUTS AND BOLTS

FM Series Threaded Rod

Part No.	Size	Max. Recommended Tensile Load (kN)	Mass kg/m
FM150-06	M6	3.47	0.20
FM150-08	M8	6.32	0.35
FM150-10	M10	10.02	0.50
FM150-12	M12	14.56	0.80
FM150-16	M16	24.30	1.30
FM150-20	M20	37.92	2.10

Standard Finish: Zinc Plated.

*Also available in Hot Dipped Galvanised.

Standard Length: 2.0m

Load Data: Maximum recommended tensile load based on a factor of safety of 2.5 using the appropriate stress area of thread and ultimate tensile strength of 430 MPa.

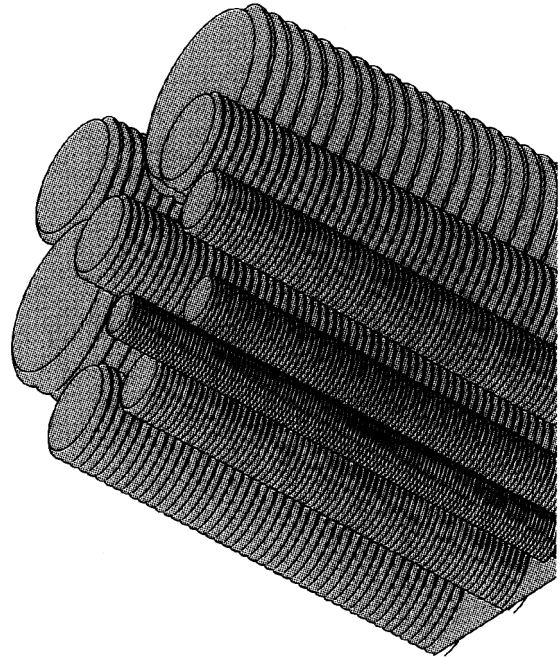

Fastening Systems &
Cantilever Brackets

Rod Couplers

Part No.	Thread	Length "A"	Mass kg/100
RC06	M6	20	1.2
RC08	M8	20	2.3
RC10*	M10	30	4.0
RC12*	M12	40	7.8
RC16*	M16	50	12.2
RC20*	M20	50	19.0

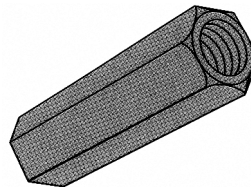

Standard Finish: Zinc Plated.

*Also available in Hot Dipped Galvanised.

MASONRY ANCHORS

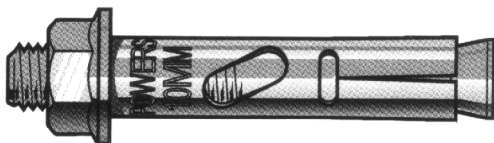

VERTIGO SCREWERS

